

Polymas

Industrial Watertight Enclosure

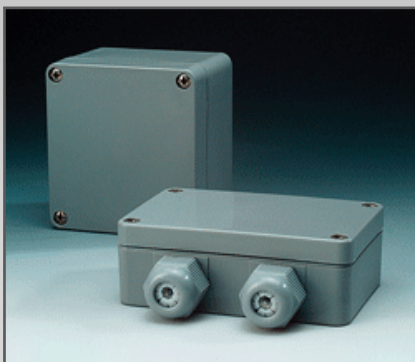

For Finishing Services, Product Support, or to Order

Call 1-301-696-9800



These small control enclosures made of 30% glassbead-reinforced polyamide are especially suitable for fitting small electronics components and terminal blocks. They are used primarily in the industrial sector.

The sturdy control enclosures, which provide good chemical resistance, are available with or without moulded-on

cable glands and with or without quick-release fastening; ingress protection IP 65 (higher protection category available on request).

Mounting bosses for self-tapping screws are provided for the assembly of terminal blocks, DIN rails or PCBs.

Enclosure material: Polyamide 6, 30% glassbead-reinforced.
For technical data see pages 646-651.

Colour: Grey, similar to RAL 7001.

Scope of delivery: Upper and lower section; lid screws made of V2A, or quick-release fastening made of nickel-plated GD-ZN A14Cu1; depending on design with moulded-on cable glands Pg 11 including clamping cage, pressure screw and closed sealing ring.

Ingress protection: IP65/DIN EN 60529; increased protection up to IP x7 on request.

Lid seal: Sponge cord (neoprene) in lid groove. For technical data see page 651.

Accessories (additional charge):

M: Mounting plate, sheet steel, galvanised

SIL: Lid with silicone seal

TS 15: Top hat rail DIN EN 60715 TH15

Notes:

- Available with transparent lid for quantities exceeding 500 units (see below)
- Cable glands, see page 614 ff.
- Tension range for moulded-on cable glands 8-10 mm
- Terminal assignment and machining on request.

Types:

PK 1... Without quick-release fastening, without moulded-on cable gland.

PK 1...-111 Without quick-release fastening, 1 moulded-on cable gland, Pg 11, side 1.

PK 1...-211 Without quick-release fastening, 2 moulded-on cable glands, Pg 11, 1x side 1+2.

PK 1...-411 Without quick-release fastening, 4 moulded-on cable glands, Pg 11, 2x side 1 (PK101).

PK 1... SV With quick-release fastening, without moulded-on cable gland.

PK 1... SV-111 With quick-release fastening, 1 moulded-on cable gland, Pg 11, side 1.

PK 1... SV-211 With quick-release fastening, 2 moulded-on cable glands, Pg 11, 2x side 1 (PK102).

PK 1... SV-411 With quick-release fastening, 4 moulded-on cable glands Pg 11, 2x side 1+2.

Enclosures		Ext. dimensions (without cable gland)		
Model	Order no.	L	W	H
PK 101*	38101000	58	64	34
PK 101-111*	38101100	58	64	34
PK 101-211*	38101200	58	64	34
PK 101 SV	38101500	58	64	34
PK 101 SV-111	38101600	58	64	34
PK 101 SV-211	38101700	58	64	34
PK 102*	38102000	98	64	34
PK 102-211*	38102200	98	64	34
PK 102-411*	38102400	98	64	34
PK 102 SV	38102500	98	64	34
PK 102 SV-211	38102700	98	64	34
PK 102 SV-411	38102900	98	64	34
PK 105*	38105000	75	80	57
PK 105 SV	38105500	75	80	57
PK 110*	38110000	125	80	57
PK 110 SV	38110500	125	80	57
PK 115*	38115000	175	80	57
PK 115 SV	38115500	175	80	57

* Also available with transparent lid for quantities exceeding 500 units.
Lid material: polycarbonate.

Euromas-Polymas

PK 101

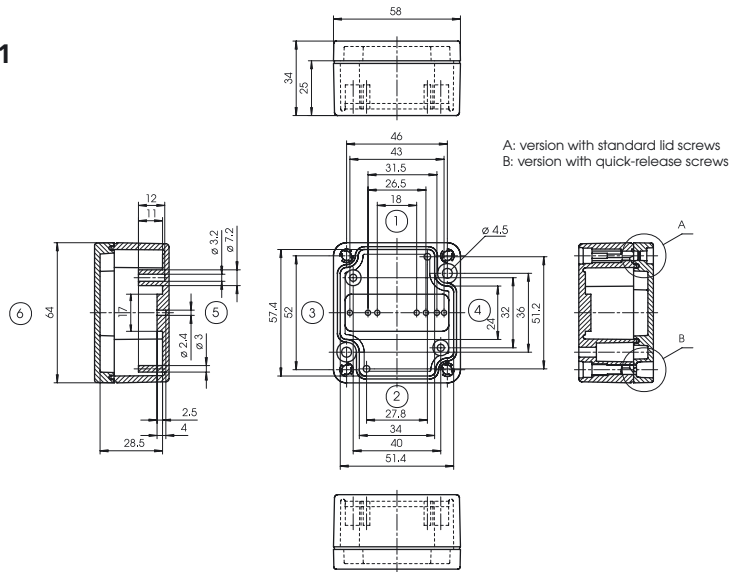

Order designation

Enclosures	Order no.
PK 101	38101000
PK 101 SV	38101500
PK 101 G	38101020*

(SV = quick-release fastening,
G = with transparent lid)

* available at minimum order qty.
exceeding 500 pcs.

Accessories (additional charge) Order no.

SIL: Lid with silicone seal	21005700
-----------------------------	----------

Z-2400381

PK 101-111

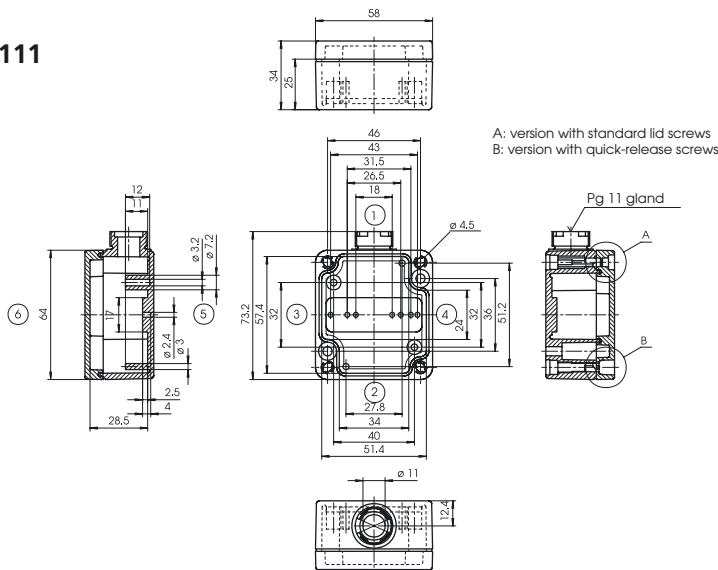

Order designation

Enclosures	Order no.
PK 101-111	38101100
PK 101-111 SV	38101600
PK 101-111 G	38101120*

(SV = quick-release fastening,
G = with transparent lid)

* available at minimum order qty.
exceeding 500 pcs.

... - 111 = Please see description on
page 457

Accessories (additional charge) Order no.

SIL: Lid with silicone seal	21005700
-----------------------------	----------

Z-2400382

PK 101-211

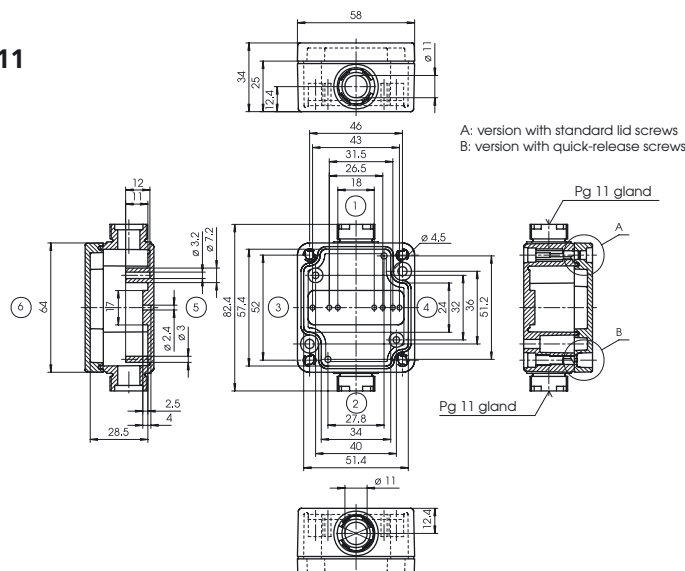

Order designation

Enclosures	Order no.
PK 101-211	38101200
PK 101-211 SV	38101700
PK 101-211 G	38101220*

(SV = quick-release fastening,
G = with transparent lid)

* available at minimum order qty.
exceeding 500 pcs.

... - 211 = Please see description on
page 457

Accessories (additional charge) Order no.

SIL: Lid with silicone seal	21005700
-----------------------------	----------

Z-2400383

Order designation

Enclosures	Order no.
PK 102	38102000
PK 102 SV	38102500
PK 102 G	38102020*

(SV = quick-release fastening,
G = with transparent lid)
* available at minimum order qty.
exceeding 500 pcs.

Accessories (additional charge)	Order no.
SIL: Lid with silicone seal	21005800

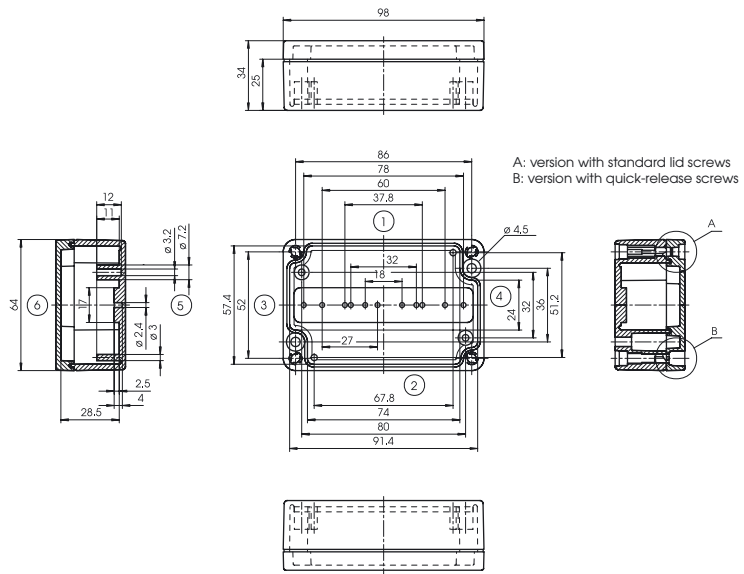

PK 102

Z-2400384

Order designation

Enclosures	Order no.
PK 102-211	38102200
PK 102-211 SV	38102700
PK 102-211 G	38102220*

(SV = quick-release fastening,
G = with transparent lid)
* available at minimum order qty.
exceeding 500 pcs.
...- 211 = Please see description on
page 457

Accessories (additional charge)	Order no.
SIL: Lid with silicone seal	21005800

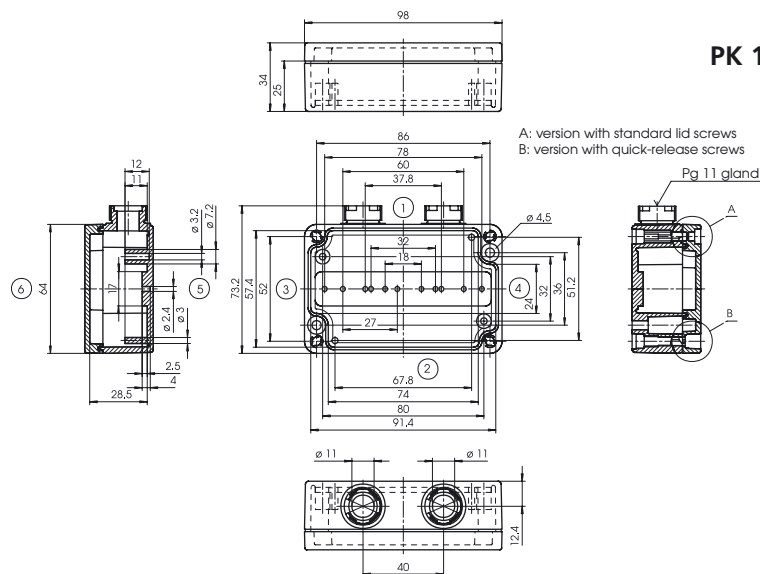

PK 102-211

Z-2400385

Order designation

Enclosures	Order no.
PK 102-411	38102400
PK 102-411 SV	38102900
PK 102-411 G	38102420*

(SV = quick-release fastening,
G = with transparent lid)
* available at minimum order qty.
exceeding 500 pcs.
...- 411 = Please see description on
page 457

Accessories (additional charge)	Order no.
SIL: Lid with silicone seal	21005800

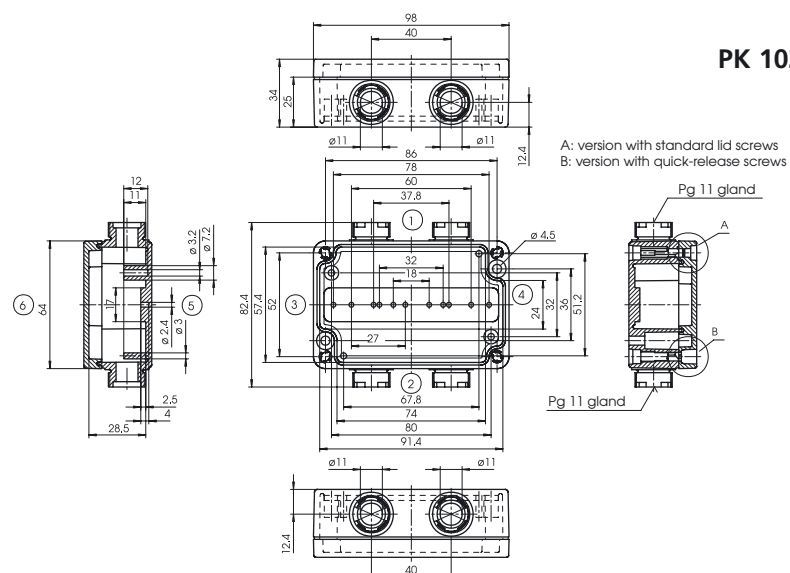

PK 102-411

Z-2400386

Euromas-Polymas

PK 105

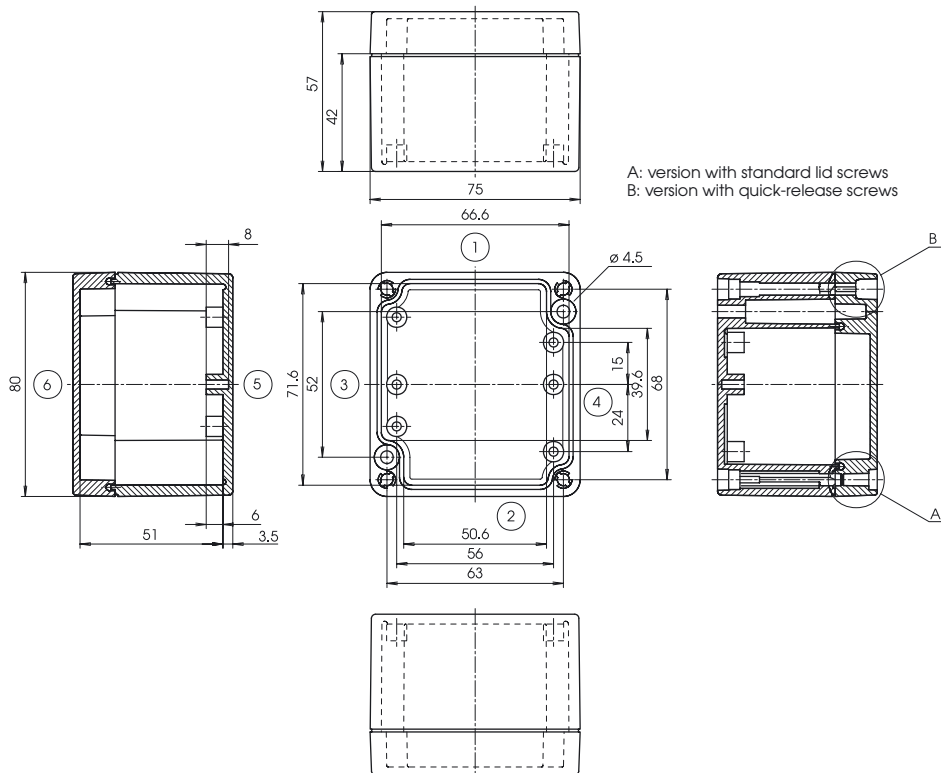

Order designation

Enclosures	Order no.
PK 105	38105000
PK 105 SV	38105500
PK 105 G	38105020*

(SV = quick-release fastening,
G = with transparent lid)
* available at minimum order qty.
exceeding 500 pcs.

Standard accessories

Standard accessories	Order no.
M: Mounting plate, sheet steel, galv.	21001100
SIL: Lid with silicone seal	21006000
TS 15: Top hat rail DIN EN 60715 TH15	21002800

Z-2400388

PK 110

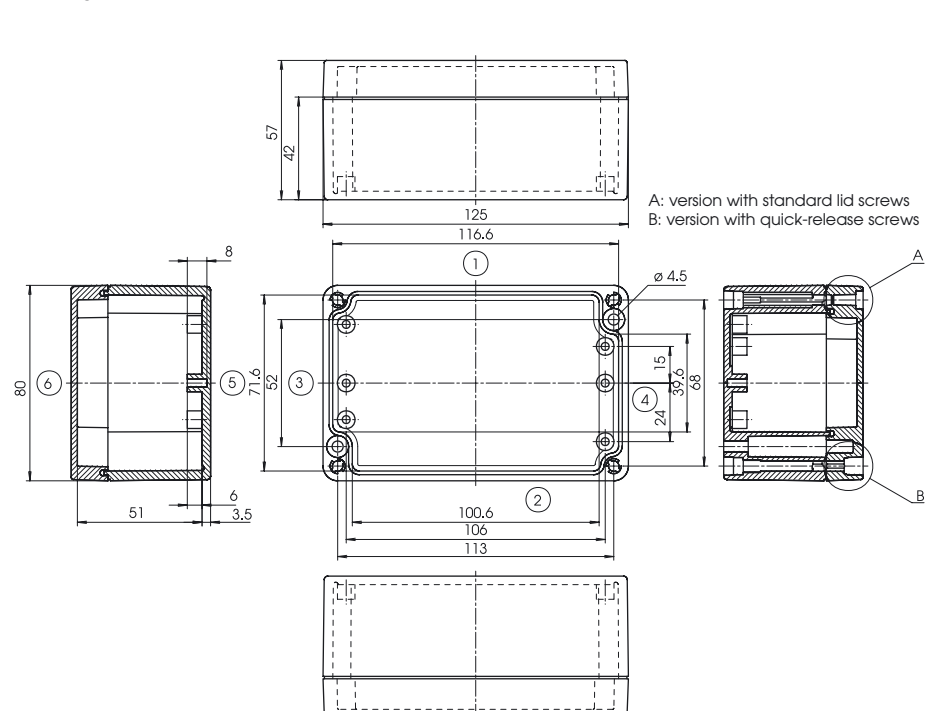

Order designation

Enclosures	Order no.
PK 110	38110000
PK 110 SV	38110500
PK 110 G	38110020*

(SV = quick-release fastening,
G = with transparent lid)
* available at minimum order qty.
exceeding 500 pcs.

Standard accessories

Standard accessories	Order no.
M: Mounting plate, sheet steel, galv.	21001200
SIL: Lid with silicone seal	21006100
TS 15: Top hat rail DIN EN 60715 TH15	21002900

Z-2400392

Order designation

Enclosures	Order no.
PK 115	38115000
PK 115 SV	38115500
PK 115 G	38115020*

(SV = quick-release fastening,
G = with transparent lid)

* available at minimum order qty.
exceeding 500 pcs.

PK 115

Standard accessories

Standard accessories	Order no.
M: Mounting plate, sheet steel, galv.	21001300
SIL: Lid with silicone seal	21006200
TS 15: Top hat rail DIN EN 60715 TH15	21003000

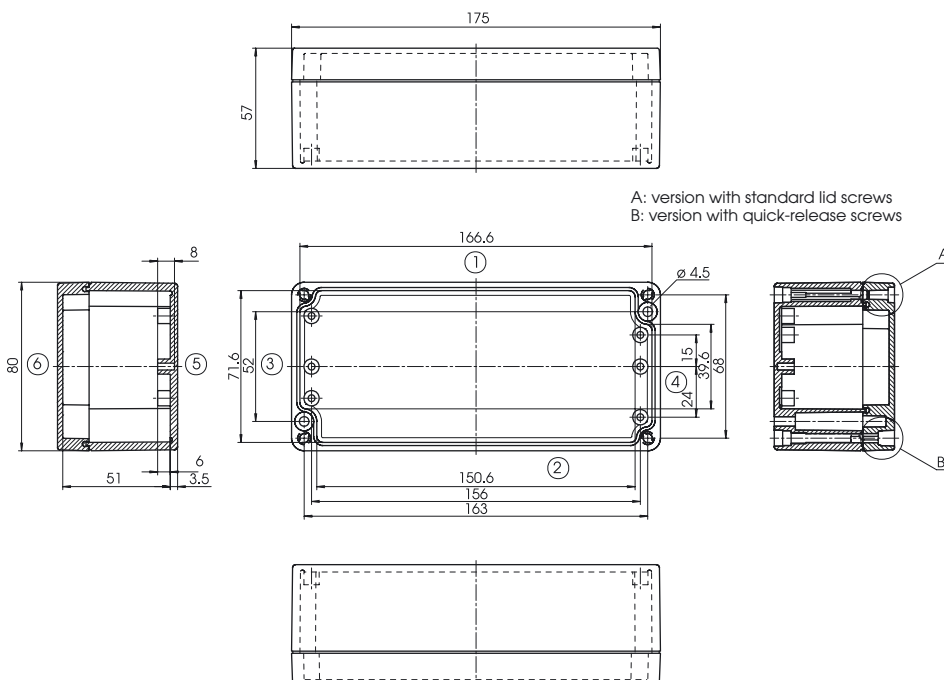

Z-2400393

