



ROSE+BOPLA
ENCLOSURES

A PHOENIX MECANO COMPANY

Mobile Control 2921 Handheld Enclosures Product Drawings Last Updated 6/20/2008

Rose+Bopla Enclosures
7330 Executive Way
Frederick, MD 21704
301-696-9800
www.rose-bopla.com
rbinfo@pm-usa.com

Dimensional Drawings

For Secondary Services, Product Support, or To Order, Call 1-301-696-9800

Handhelds



Rose+Bopla's 2921 Mobile Control Units are similar to the 2930 and 2940 Mobile Control Units, but are offered with five different sized heads to suit a wide variety of control requirements.

Mobile Control Units 2921

Modern engineering facilities use membrane panels for mobile controlling and installation. The 2921 series enclosures offer ideal mounting capabilities for membrane keypads or electro-mechanical components.

With their graded sizes, custom front panels can be designed for mounting push buttons or membrane keypads as required. Ergonomically shaped handles offer improved handling and impact-resistant polyamide material make 2921 Mobile Control Units ideal for tough industrial settings.

Each unit consists of an enclosure body, a removable front panel with stamped Neoprene gasket, flat-head screws, wall-mount bracket with hardware, and M20 power cord cable grip. The 2921 Mobile Control enclosure has a pre-threaded hole for the cable grip at the bottom. If the grip is not required, it may be filled with a Rose hole plug. Cable grips are designed to give bending protection and strain relief. As an option, a self-adhesive magnet can be attached to the rear of the enclosure.

TECHNICAL DATA:

- Body material: Polyamide
- Cable gland material: Polyamide M20
- Front panel material: black Polyester
- Body color: yellow, similar to RAL 1021
- Ingress Protection: IP 65 to EN 60529, NEMA 12
- Impact resistance: > 7 Nm, EN 50014
- Gasket material: stamped foam rubber gasket
- Temperature resistance: -40°F to +140°F

Mobile Control Units 2921 Series					
Part Number	Depth (Inches/mm)	Width (Inches/mm)	Height (Inches/mm)	Weight	Drawing
29211000	3.35 / 85	3.35 / 85	8.11 / 206	.68 lbs	17-119
29212000	3.35 / 85	4.53 / 115	8.11 / 206	.75 lbs	17-120
29213000	3.35 / 85	3.35 / 85	9.29 / 235	.75 lbs	17-120
29214000	3.35 / 85	6.30 / 160	8.90 / 226	.96 lbs	17-121
29215000	3.35 / 85	4.13 / 105	11.06 / 281	.96 lbs	17-121

Note: Dimensions are external. Metric is the primary dimension. Inch conversions are for the user's convenience and are for reference only. Accessories shown on drawing page.



2921 Mobile Control Units are membrane keypad ready.



Integrated handle is designed for use with wall bracket.



Self-adhesive magnetic holder is available as an option.

Control Units

29212000

External Dimensions: L206 x W115 x H85 mm

Page 4-14

Standard Features
<ul style="list-style-type: none"> • 29212000 Enclosure body with handle, front panel with screws, cable gland M20 with bending protection and wall mount bracket.
Accessories
<ul style="list-style-type: none"> • 10094657 External wall mounting bracket. • 08100120 Extra cable grip with strain protection M20. • 29000080 Magnetic holder, self-adhesive. • 10095167 Front plate.

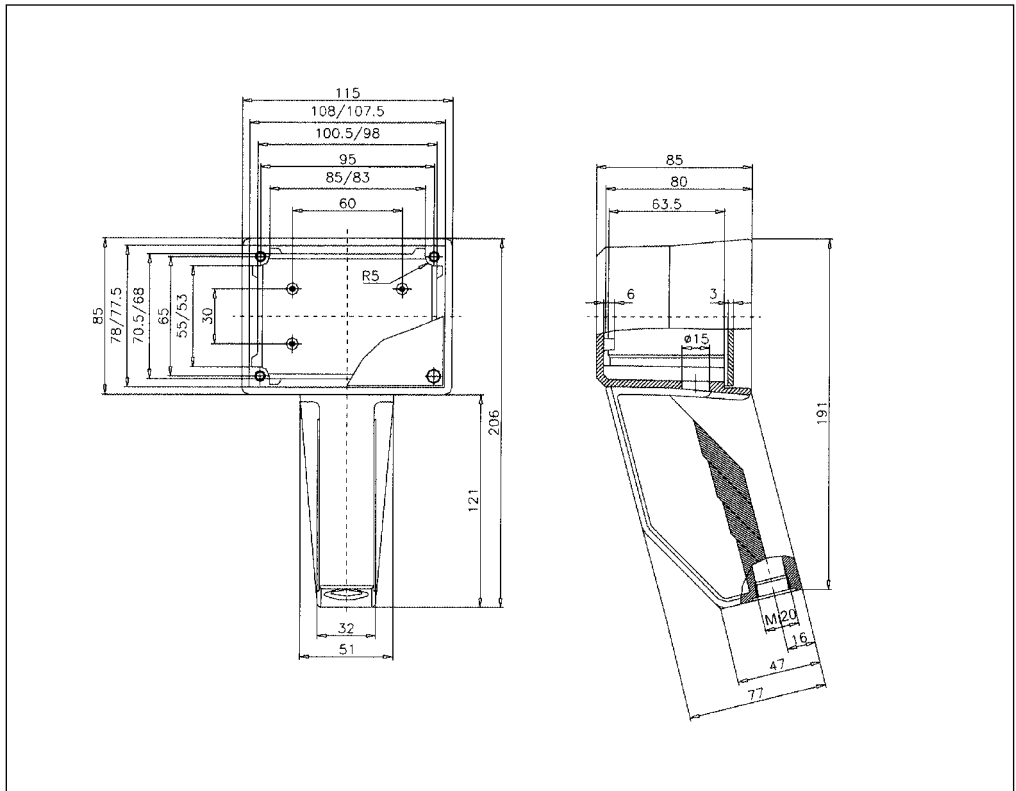

29213000

External Dimensions: L236 x W115 x H85 mm

Page 4-14

Standard Features
<ul style="list-style-type: none"> • 29213000 Enclosure body with handle, front panel with screws, cable gland M20 with bending protection and wall mount bracket.
Accessories
<ul style="list-style-type: none"> • 10094657 External wall mounting bracket. • 08100120 Extra cable grip with strain protection M20. • 29000080 Magnetic holder, self adhesive. • 10095167 Front plate.

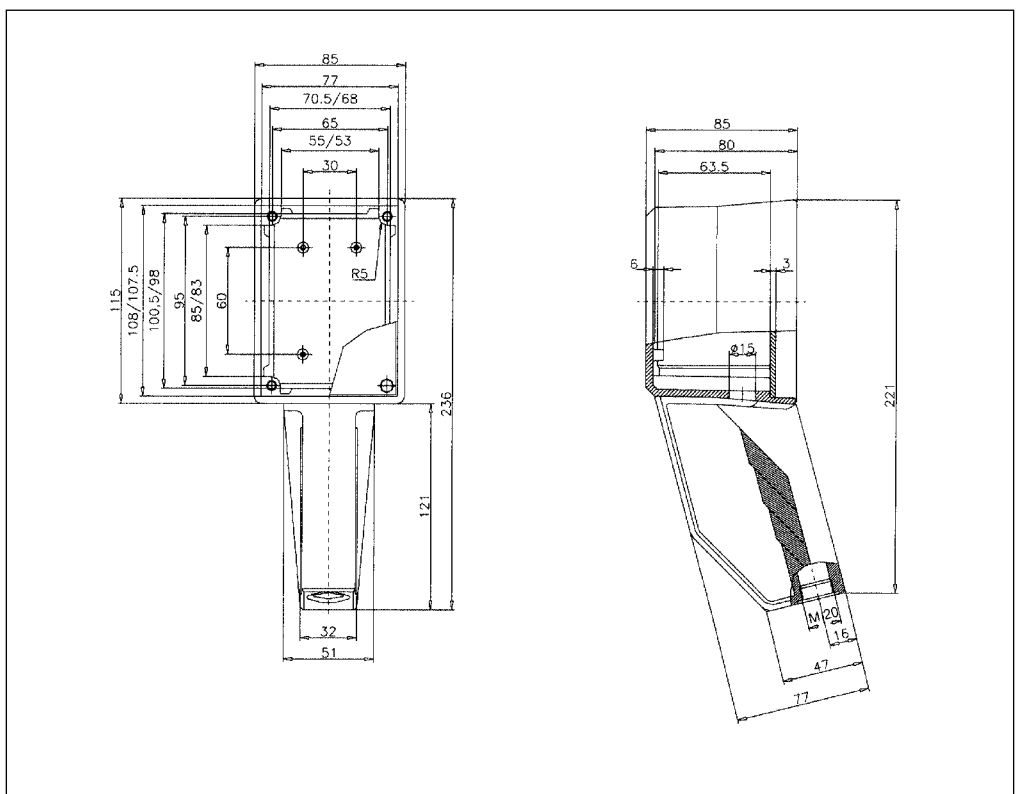



29214000

External Dimensions: L226 x W160 x H85 mm

Page 4-14

Standard Features
<ul style="list-style-type: none"> • 29214000 Enclosure body with handle, front panel with screws, cable gland M20 with bending protection and wall mount bracket.
Accessories
<ul style="list-style-type: none"> • 08100120 Extra cable grip with strain protection M20. • 29000080 Magnetic holder, self adhesive. • 10094657 External wall mounting bracket. • 10095168 Front plate.

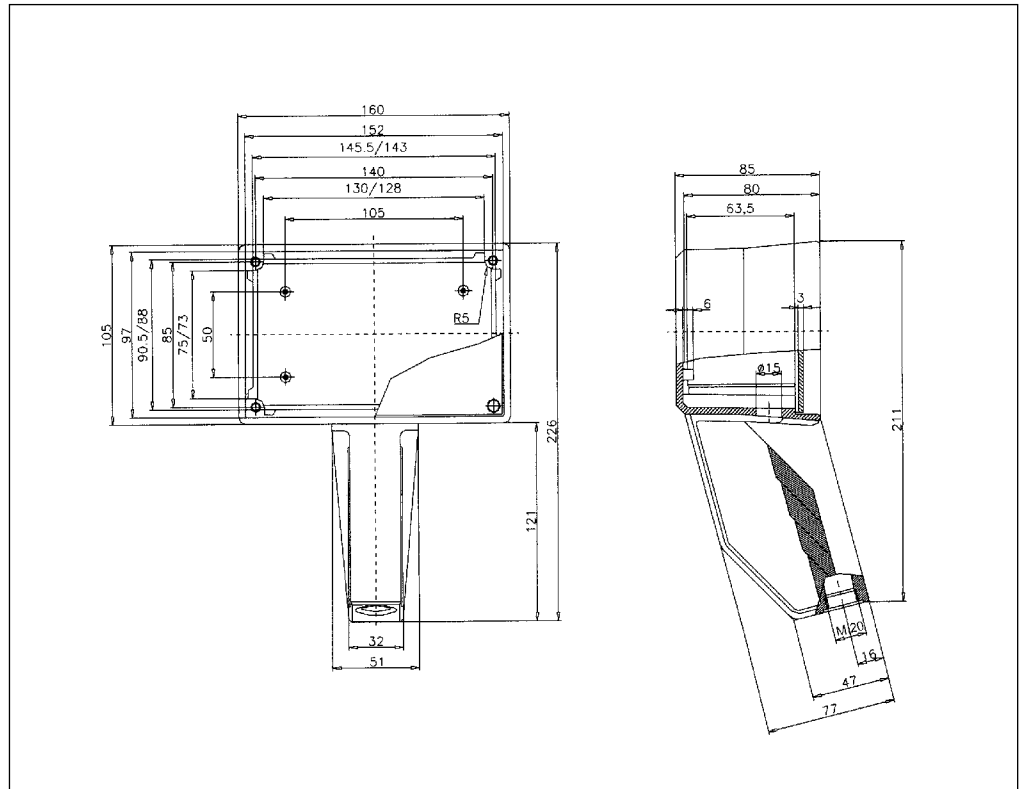

29215000

External Dimensions: L281 x W105 x H85 mm

Page 4-14

Standard Features
<ul style="list-style-type: none"> • 29215000 Enclosure body with handle, front panel with screws, cable gland M20 with bending protection and wall mount bracket.
Accessories
<ul style="list-style-type: none"> • 08100120 Extra cable grip with strain protection M20. • 29000080 Magnetic holder, self adhesive. • 10094657 External wall mounting bracket.

