



**ROSE+BOPLA**  
ENCLOSURES

A PHOENIX MECANO COMPANY

# Ultramas Enclosures Product Drawings Last Updated 6/13/2008

Rose+Bopla Enclosures  
7330 Executive Way  
Frederick, MD 21704  
301-696-9800  
[www.rose-bopla.com](http://www.rose-bopla.com)  
[rbinfo@pm-usa.com](mailto:rbinfo@pm-usa.com)

*Dimensional Drawings*

*For Secondary Services, Product Support, or To Order, Call 1-301-696-9800*



These stylish enclosures, ideal for small test equipment and computer peripherals, are easily adapted to your individual space requirements. Ultramas offers many different dimensions and

## Ultramas

height options to satisfy a wide range of applications. Ultramas is comfortable in either the horizontal or vertical position, making it perfect as a desk or wall enclosure.

The enclosure features smooth design lines, flawless satin finish and is offered with or without ventilation slots. Front/rear panels (2mm thick), in anodized aluminum or ABS plastic, are available as accessories. Other accessories include: internal card frames to accept 100mm and 233.35mm boards in 160mm and 220mm depths. These enclosures, made of ABS plastic, come in three basic heights and two depths. Height can be extended in 1.8" increments by adding optional side spacer sections. Recessed surfaces on the top parts are designed to accommodate displays and operating elements, in particular, flush fitting membrane keypads. Units are secured with M3 screws, which thread into pressed-in inserts. Screws are concealed beneath internal screw covers (medium gray). Fixed support feet or prop-up feet are also available as accessories.



### TECHNICAL DATA:

- Color: enclosure in light gray, similar to RAL 7035. Screw covers, brackets and feet in agate gray, similar to RAL 7038.
- Material: ABS plastic
- Protection Classifications: Closed, IP40/DIN VDE 0470. With air vents, IP30/DIN VDE 0470.
- Surface Resistance:  $>10^{14}$  Ohm to DIN 53482
- Disruptive Strength: 17KV/mm to DIN 53481
- Flammability: UL 94 HB/1.6

Ultramas						
Model Number	Part Number	Width (Inches/mm)	Depth (Inches/mm)	Height (Inches/mm)	Weight lbs.	Drawing
UM 32009	55320000	6.20 / 157.5	7.83 / 198.9	2.45 / 62.2	.946	17-198
UM 32009 L	55320010	6.20 / 157.5	7.83 / 198.9	2.45 / 62.2	.922	17-198
UM 32609	55326000	6.20 / 157.5	10.19 / 258.9	2.45 / 62.2	1.213	17-198
UM 32609 L	55326010	6.20 / 157.5	10.19 / 258.9	2.45 / 62.2	1.186	17-198
UM 52011	55520000	8.83 / 224.2	7.83 / 198.9	2.83 / 72.4	1.312	17-199
UM 52011 L	55520020	8.83 / 224.2	7.83 / 198.9	2.83 / 72.4	1.239	17-199
UM 62009	55620000	11.45 / 290.9	7.83 / 198.9	2.45 / 62.2	1.462	17-200
UM 62009 L	55620010	11.45 / 290.9	7.83 / 198.9	2.45 / 62.2	1.378	17-200
UM 62609	55626000	11.45 / 290.9	10.19 / 258.9	2.45 / 62.2	1.790	17-200
UM 62609 L	55626010	11.45 / 290.9	10.19 / 258.9	2.45 / 62.2	1.808	17-200

L=molded-in air vents in lid and base

Note: Dimensions are external. Metric is the primary dimension. Inch conversions are for the user's convenience and are for reference only.

Accessories shown on drawing page.

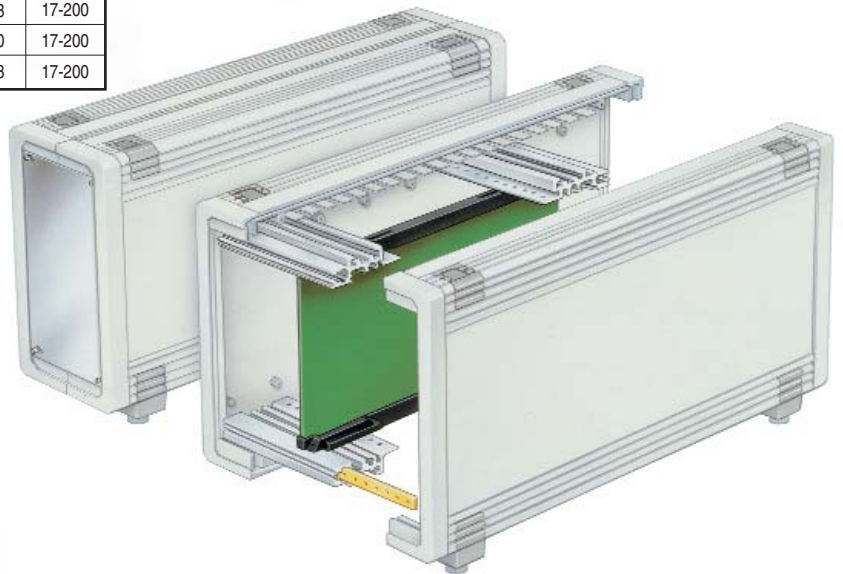

## Ultramas UM 3...09



Ultramas, UM3...09, without air vents



Ultramas, UM3...09, with air vents in lid and base

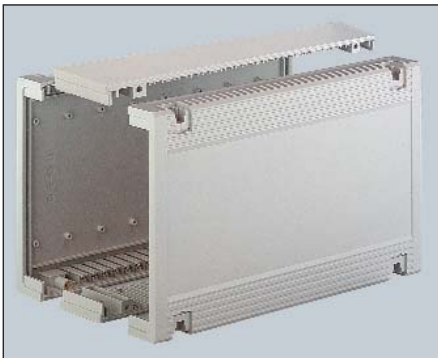

Ultramas Enclosures, UM 3...09						
Model Number	Part Number	Width (Inches/mm)	Height (Inches/mm)	Depth (Inches/mm)	Weight lbs.	Drawing Page #
UM 32009	55320000	6.20 / 157.5	2.45 / 62.2	7.83 / 198.9	.946	17-198
UM 32009 L	55320010	6.20 / 157.5	2.45 / 62.2	7.83 / 198.9	.922	17-198
UM 32609	55326000	6.20 / 157.5	2.45 / 62.2	10.19 / 258.9	1.213	17-198
UM 32609 L	55326010	6.20 / 157.5	2.45 / 62.2	10.19 / 258.9	1.186	17-198

L=with molded-in air vents in lid and base

The usable basic enclosure height of 46.5mm, in horizontal use, can be increased by using extension sets AB.... Front panels must be chosen to match the selected enclosure width.

**Including:** Two half-shells, eight covers, four rubber feet, and four M3 screws.

Accessories shown on drawing page.

UM 3...09 Selection Table For Front Panels and Extension Sets				
Usable Enclosure Height	Number of Extension Sets		Front Panels To Be Used	Drawing Page #
	AS 02...03	AB 02...09(L)		
46.5 mm	–	–	FP(K) 30009	17-198
61.7 mm	1	–	FP(K) 30012	17-198
92.2 mm	–	1	FP(K) 30018	17-198
107.5 mm	1	1	FP(K) 30021	17-198
138.0 mm	–	2	FP(K) 30027	17-198
153.2 mm	1	2	FP(K) 30030	17-198
183.7 mm	–	3	FP(K) 30036	17-198

Ultramas Plug-in Front Panels For UM 3...09							
Model Number	Part Number	Model Number	Part Number	Height (Inches/mm)	Width (Inches/mm)	Weight lbs.	Drawing Page #
FP 30009	56030900	FPK 30009	56030191	2.22 / 56.3	5.87 / 149	.037	17-198
FP 30012	56031200	FPK 30012	56031210	2.81 / 71.5	5.87 / 149	.046	17-198
FP 30018	56031800	FPK 30018	56031810	4.01 / 102.0	5.87 / 149	.068	17-198
FP 30021	56032100	FPK 30021	56032110	4.61 / 117.2	5.87 / 149	.079	17-198
FP 30027	56032700	FPK 30027	56032710	5.81 / 147.7	5.87 / 149	.099	17-198
FP 30030	56033000	FPK 30030	56033010	6.41 / 162.9	5.87 / 149	.110	17-198
FP30036	56033600	FPK 30036	56033610	7.61 / 193.4	5.87 / 149	.130	17-198

FP=Anodized aluminum, 2.0mm thick FPK=ABS Plastic, 2.0mm thick, embossed on one side

Front panels must be chosen to match the selected extension sets. Please refer to selection table.

Ultramas Extension Sets AB... For UM 3...09					
Model Number	Part Number	Extension Height (Inches/mm)	Enclosure Depth (Inches/mm)	Weight lbs.	Drawing Page #
AB 02003	56020500	0.60 / 15.24	7.83 / 198.9	.209	17-198
AB 02009	56020000	1.80 / 45.72	7.83 / 198.9	.209	17-198
AB 02009 L	56020010	1.80 / 45.72	7.83 / 198.9	.194	17-198
AB 02603	56026500	0.60 / 15.24	10.19 / 258.9	.260	17-198
AB 02609	56026000	1.80 / 45.72	10.19 / 258.9	.260	17-198
AB 02609 L	56026010	1.80 / 45.72	10.19 / 258.9	.249	17-198

L = with molded-in air vents in lid and base

Extension Sets make it possible to extend the Ultramas enclosure between the half shells.

**Including:** Two extension units, assembly material

Note: Dimensions are external. Metric is the primary dimension. Inch conversions are for the user's convenience and are for reference only.

## Ultramas UM 5...11

Ultramas Enclosures, UM 5...						
Model Number	Part Number	Width (Inches/mm)	Height (Inches/mm)	Depth (Inches/mm)	Weight lbs.	Drawing Page #
UM 52011	55520000	8.83 / 224.2	2.85 / 72.4	7.83 / 198.9	1.312	17-199
UM 52011 L	55520020	8.83 / 224.2	2.85 / 72.4	7.83 / 198.9	1.239	17-199

L=with molded-in air vents in lid and base

The usable basic enclosure height of 56.7mm, in horizontal use, can be increased by using extension sets AB.... Front panels must be chosen to match the selected enclosure width.

**Including:** Two half-shells, eight covers, four rubber feet, and four M3 screws.  
Accessories shown on drawing page.



Ultramas, UM5..., without air vents

UM 5... Selection Table For Front Panels and Extension Sets			
Usable Enclosure Height	Number of Extension Sets AB 02009 (L)	Front Panels To Be Used	Drawing Page #
56.7 mm	–	FP(K) 50011	17-199
102.4 mm	1	FP(K) 50020	17-199
148.1 mm	2	FP(K) 50029	17-199

Ultramas Plug-in Front Panels For UM 5...							
Model Number	Part Number	Model Number	Part Number	Height (Inches/mm)	Width (Inches/mm)	Weight lbs.	Drawing Page #
FP 50011	56051100	FPK 50011	56051110	8.49 / 215.6	2.61 / 66.4	.066	17-199
FP 50020	56052000	FPK 50020	56052010	8.49 / 215.6	4.42 / 112.2	.110	17-199
FP 50029	56052900	FPK 50029	56052910	8.49 / 215.6	6.22 / 157.9	.152	17-199

FP=Anodized aluminum, 2.0mm thick      FPK=ABS Plastic, 2.0mm thick, embossed on one side

Front panels must be chosen to match the selected extension sets. Please refer to selection table.



Ultramas, UM5..., with air vents

Ultramas Extension Sets AB... For UM 5...					
Model Number	Part Number	Extension Height (Inches/mm)	Enclosure Depth (Inches/mm)	Weight lbs.	Drawing Page #
AB 02009	56020000	1.80 / 45.72	7.83 / 198.9	.209	17-199
AB 02009 L	56020010	1.80 / 45.72	7.83 / 198.9	.194	17-199

L = with molded-in air vents in lid and base

Extension Sets make it possible to extend the Ultramas enclosure between the half shells.

**Including:** Two extension units, assembly material

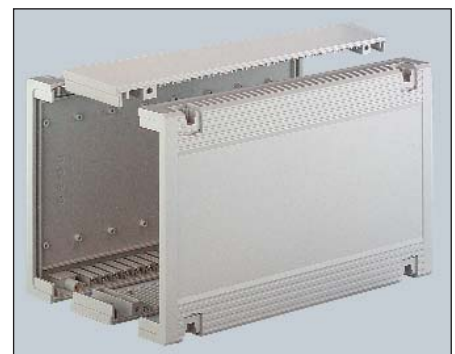

Note: Dimensions are external. Metric is the primary dimension. Inch conversions are for the user's convenience and are for reference only.

## Ultramas UM 6...09



Ultramas, UM6...09, without air vents



Ultramas, UM6...09, with air vents

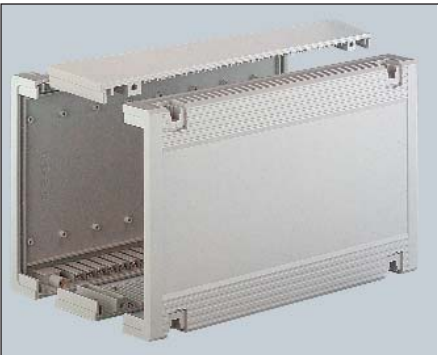

Ultramas Enclosures, UM 6...09						
Model Number	Part Number	Width (Inches/mm)	Height (Inches/mm)	Depth (Inches/mm)	Weight lbs.	Drawing Page #
UM 62009	55620000	11.45 / 290.9	2.45 / 62.2	7.83 / 198.9	1.462	17-200
UM 62009 L	55620010	11.45 / 290.9	2.45 / 62.2	7.83 / 198.9	1.378	17-200
UM 62609	55626000	11.45 / 290.9	2.45 / 62.2	10.19 / 258.9	1.790	17-200
UM 62609 L	55626010	11.45 / 290.9	2.45 / 62.2	10.19 / 258.9	1.808	17-200

L=with molded-in air vents in lid and base

The usable basic enclosure height of 46.5mm, in horizontal use, can be increased by using extension sets AB... Front panels must be chosen to match the selected enclosure width.

**Including:** Two half-shells, eight covers, four rubber feet, and four M3 screws.

Accessories shown on drawing page.

UM 6...09 Selection Table For Front Panels and Extension Sets				
Usable Enclosure Height	Number of Extension Sets		Front Panels To Be Used	Drawing Page #
	AS 02...03	AB 02...09(L)		
46.5 mm	–	–	FP(K) 60009	17-200
61.7 mm	1	–	FP(K) 60012	17-200
92.2 mm	–	1	FP(K) 60018	17-200
107.5 mm	1	1	FP(K) 60021	17-200
138.0 mm	–	2	FP(K) 60027	17-200
153.2 mm	1	2	FP(K) 60030	17-200
183.7 mm	–	3	FP(K) 60036	17-200

Ultramas Plug-in Front Panels For UM 6...09							
Model Number	Part Number	Model Number	Part Number	Height (Inches/mm)	Width (Inches/mm)	Weight lbs.	Drawing Page #
FP 60009	56060900	FPK 60009	56060910	2.22 / 56.3	11.11 / 282.3	.075	17-200
FP 60012	56061200	FPK 60012	56061210	2.81 / 71.5	11.11 / 282.3	.093	17-200
FP 60018	56061800	FPK 60018	56061810	4.01 / 102.0	11.11 / 282.3	.135	17-200
FP 60021	56062100	FPK 60021	56062110	4.61 / 117.2	11.11 / 282.3	.148	17-200
FP 60027	56062700	FPK 60027	56062710	5.81 / 147.7	11.11 / 282.3	.201	17-200
FP 60030	56063000	FPK 60030	56063010	6.41 / 162.9	11.11 / 282.3	.207	17-200
FP60036	56063600	FPK 60036	56063610	7.61 / 193.4	11.11 / 282.3	.262	17-200

FP=Anodized aluminum, 2.0mm thick FPK=ABS Plastic, 2.0mm thick, embossed on one side

Front panels must be chosen to match the selected extension sets. Please refer to selection table.

Ultramas Extension Sets AB... For UM 6...09					
Model Number	Part Number	Extension Height (Inches/mm)	Enclosure Depth (Inches/mm)	Weight lbs.	Drawing Page #
AB 02003	56020500	0.60 / 15.24	7.83 / 198.9	.209	17-200
AB 02009	56020000	1.80 / 45.72	7.83 / 198.9	.209	17-200
AB 02009 L	56020010	1.80 / 45.72	7.83 / 198.9	.194	17-200
AB 02603	56026500	0.60 / 15.24	10.19 / 258.9	.260	17-200
AB 02609	56026000	1.80 / 45.72	10.19 / 258.9	.260	17-200
AB 02609 L	56026010	1.80 / 45.72	10.19 / 258.9	.249	17-200

L = with molded-in air vents in lid and base

Extension Sets make it possible to extend the Ultramas enclosure between the half shells.

**Including:** Two extension units, assembly material

Note: Dimensions are external. Metric is the primary dimension. Inch conversions are for the user's convenience and are for reference only.

## Ultramas Accessories



**UM-AS Fixed Set-up Foot Set**

### UM-AS Fixed Set-up Foot Set

This set consists of four fixed set-up feet that can be used as an alternative to the covers on the lower side of the base. This gives the enclosure increased ground clearance, for improved ventilation from the lower side. The feet can be fitted for horizontal or vertical enclosure use, depending on the application.

### UM-ASK Hinged Set-up Foot Set

This set consists of two hinged feet and two fixed set-up feet that can be used as an alternative to the covers on the lower side of the base. This means that the enclosure can be positioned at an angle. The feet can be fitted for horizontal or vertical enclosure use, depending on the application.



**UM-ASK Hinged Set-up Foot Set**

### UM-VHH Connecting Strap

These connecting straps can be used to screw Ultramas enclosures to each other in a horizontal position.

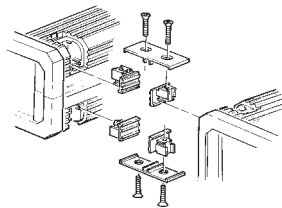

**UM-VHH Connecting Strap**

### Ultramas Wall Bracket, UM-320-WLH Assembly Dimensions

Model Number	Part Number	For Model	Width (Inches/mm)	Depth (Inches/mm)	Weight lbs.	Drawing Page #
UM-WLH	56002000	320...	6.75 / 171.50	5.90 / 150	.042	17-201
UM-WLH	56002000	326...	6.75 / 171.50	8.27 / 210	.042	17-201
UM-WLH	56002000	520...	9.38 / 238.18	5.90 / 150	.042	17-201
UM-WLH	56002000	620...	12.00 / 304.85	5.90 / 150	.042	17-201
UM-WLH	56002000	626...	12.00 / 304.85	8.27 / 210	.042	17-201



Note: Dimensions are external. Metric is the primary dimension. Inch conversions are for the user's convenience and are for reference only.





**Standard Features**

Modular ABS enclosure system, light gray, similar to RAL 7035. Includes two half shells, eight covers, four rubber feet and four M3 screws. The usable enclosure height of 56.7 mm (in horizontal use), can be increased by use of extension sets AB..., listed on page 5- 45. Front panels must be chosen to match selected enclosure width.

- UM 52011/55520000
- UM 52011 L/55520020 With molded-in air vents.

**Accessories**

- UM-AS/56012000 Fixed set up feet (set of four).
- UM-ASK/56012100 Hinged set up feet, consists of two hinged and two fixed.
- UM-1230-WLH/56002000 Wall Bracket.
- UM-1230-VHH/56002200 Connecting Strap.

**Ultramas Half Shells-UM 5**

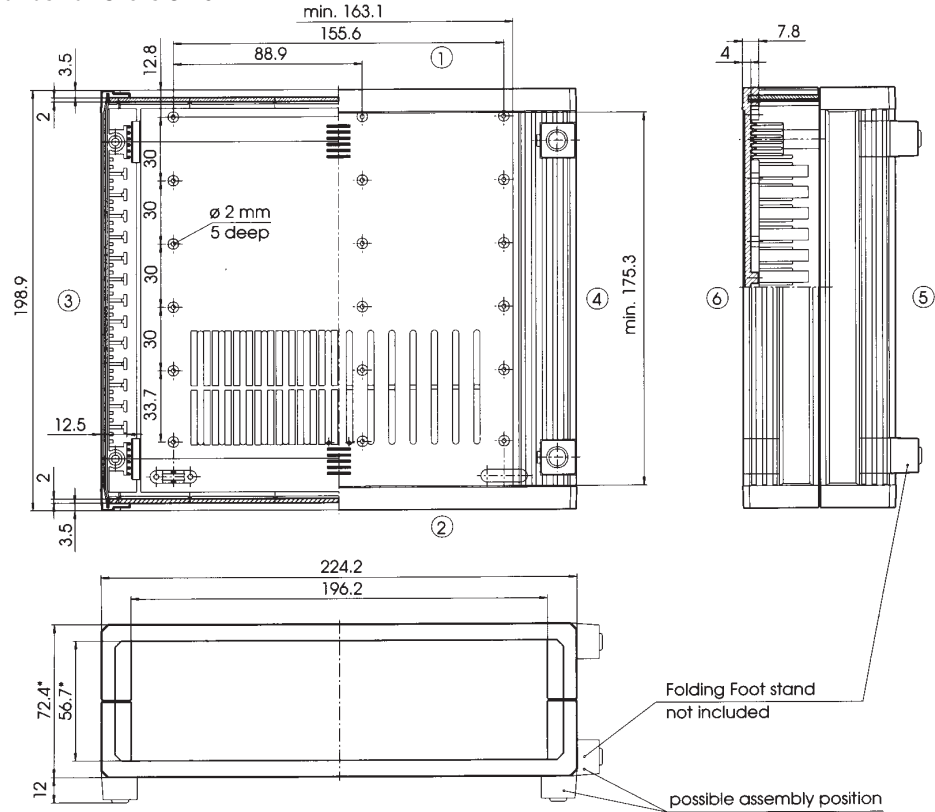

**Extension Set Assembly Drawing**

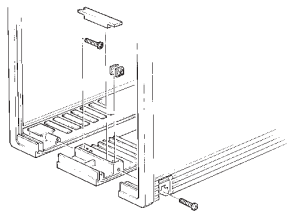

Extension Set Chart			
Model Number	Part Number	Extension Height	T=Enclosure Depth
AB 02009	56020000	45.72 mm	198.9
AB 02009L	56020010	45.72 mm	198.9

**Extension Sets**

AB 02\_09 (L)

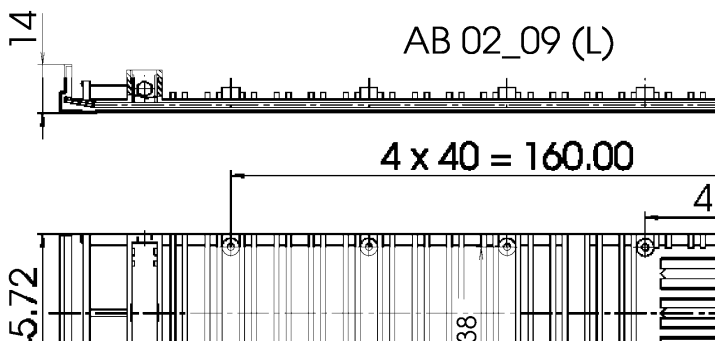

**Front Panels**

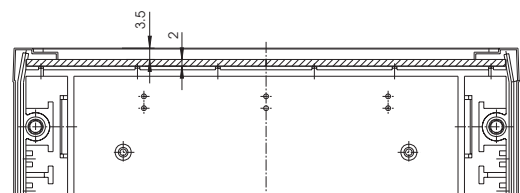

Model	Part #	Model	Part #	H	D
FP 50011	56051100	FPK 50011	56051110	215.6 mm	66.4 mm
FP 50020	56052000	FPK 50020	56052010	215.6 mm	112.2 mm
FP 50029	56052900	FPK 50029	56052910	215.6 mm	157.9 mm

Note: FP-Anodized Aluminum 2.0 mm thick.  
FPK-Plastic, 2.0 mm thick, embossed on one side.

# Ultramas

**Standard Features**

Modular ABS enclosure system, light gray, similar to RAL 7035. Includes two half shells, eight covers, four rubber feet and four M3 screws. The usable enclosure height of 46.5 mm (in horizontal use), can be increased by use of extension sets AB..., listed on page 5- 46. Front panels must be chosen to match selected enclosure width.

- UM 62009/55620000
- UM 62009 L/55620010 With molded-in air vents.
- UM 62609/55626000
- UM 62609 L/55626010 With molded-in air vents.

**Accessories**

- UM-AS/56012000 Fixed set up feet (set of four).
- UM-ASK/56012100 Hinged set up feet, consists of two hinged and two fixed.
- UM-1230-WLH/56002000 Wall Bracket.
- UM-1230-VHH/56002200 Connecting Strap.

## Ultramas Half Shells-UM6

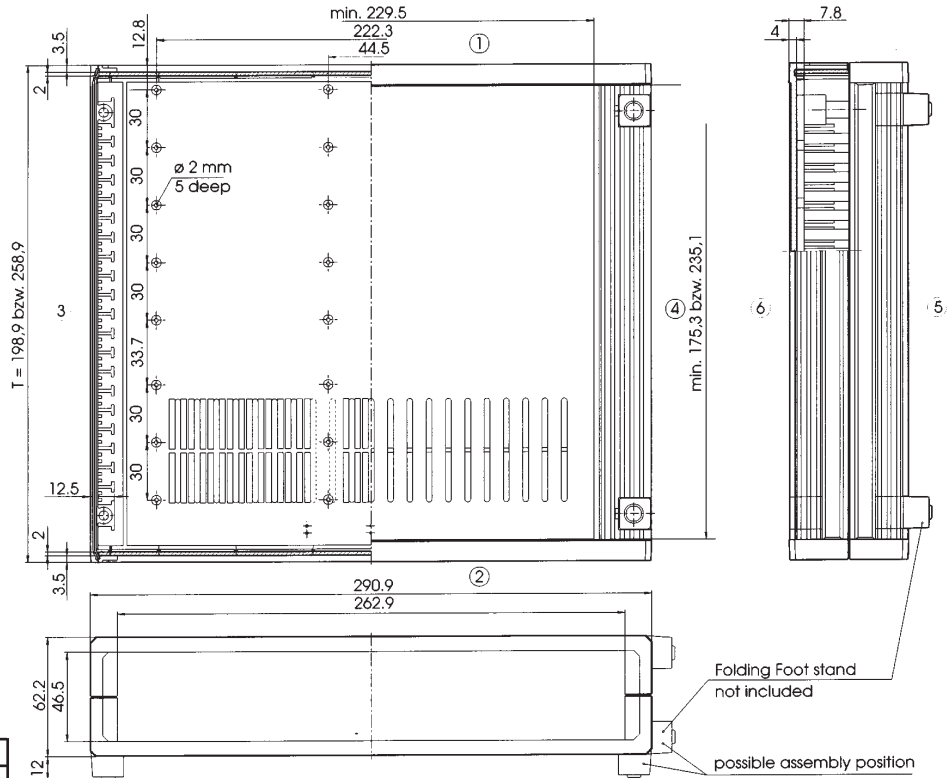

### Extension Set Assembly Drawing

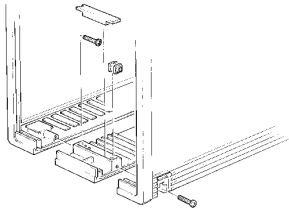

Extension Set Chart			
Model Number	Part Number	Extension Height	T=Enclosure Depth
AB 02003	56020500	15.24 mm	198.9
AB 02009	56020000	45.72 mm	198.9
AB 02009 L	56020010	45.72 mm	198.9
AB 02603	56026500	15.24 mm	258.9
AB 02609	56026000	45.72 mm	258.9
AB 02609 L	56026010	45.72 mm	258.9

### Extension Sets

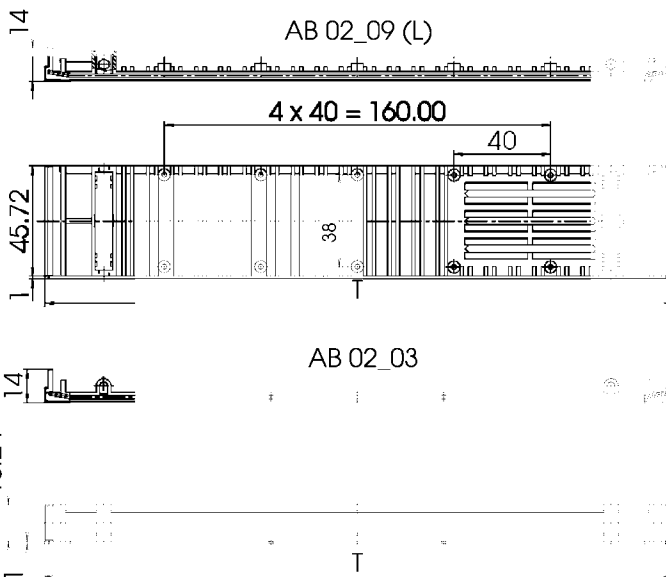

### Front Panels

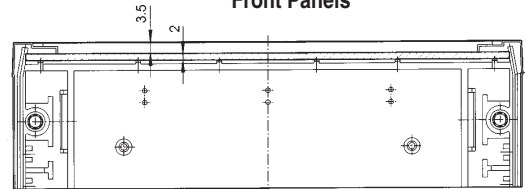

Model	Part #	Model	Part #	H	W
FP 60009	56060900	FPK 60009	56060910	56.3 mm	282.3 mm
FP 60012	56061200	FPK 60012	56061210	71.5 mm	282.3 mm
FP 60018	56061800	FPK 60018	56061810	102.0 mm	282.3 mm
FP 60021	56062100	FPK 60021	56062110	117.2 mm	282.3 mm
FP 60027	56062700	FPK 60027	56062710	147.7 mm	282.3 mm
FP 60030	56063000	FPK 60030	56063010	162.9 mm	282.3 mm
FP 60036	56063600	FPK 60036	56063610	193.4 mm	282.3 mm

Note: FP-Anodized Aluminum 2.0 mm thick.  
FPK-Plastic, 2.0 mm thick, embossed one side.



**Accessories**

- **UM-1230-WLH/56002000** Wall bracket. Brackets can be used to fit UM enclosures against the wall. Fitting by means of side insertion of the intermediate piece and screwing on the bracket. This does not affect the enclosure screwing system.
- **UM-AS/56012000** Fixed set up feet (set of four). Can be used as an alternative to the covers on the lower side of the base. This gives the enclosure increased ground clearance. Feet can be mounted for horizontal or vertical use.
- **UM-ASK/56012100** Hinged set up feet. Set consists of two hinged feet and two fixed feet. Can be used as an alternative to the covers on the lower side of the base. This gives the enclosure increased ground clearance. Feet can be mounted for horizontal or vertical use.
- **UM-1230-VHH/56002200** Connecting straps. These straps can be used to screw UM enclosures to each other in a horizontal position.

**Wall Bracket WLH**

Model	T	B
320 ..	171.5	150
326 ..	171.5	210
520 ..	238.18	150
620 ..	304.85	150
626 ..	304.85	210

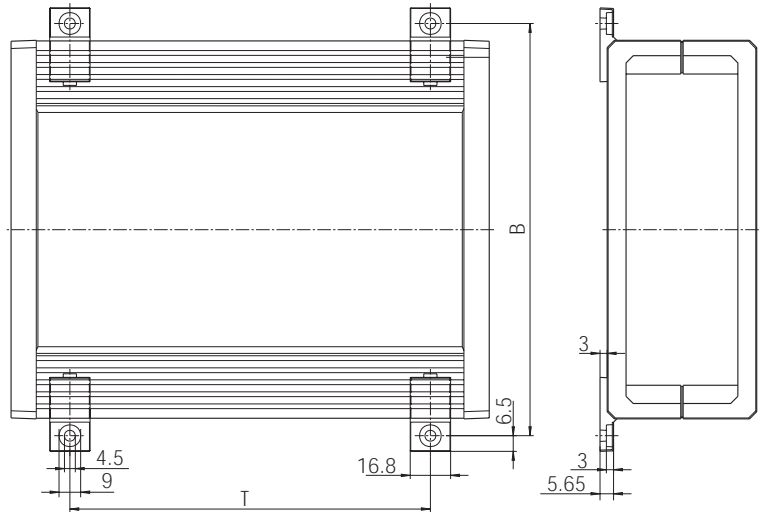

**Fixed Set-up Foot set UM-AS**



**Assembly Drawing for Foot Sets**

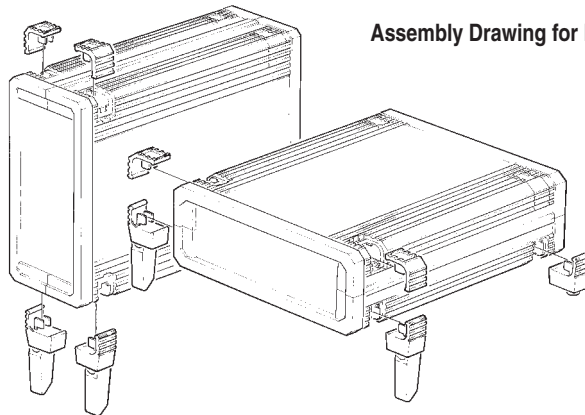

**Hinged Set-up Foot set UM-ASK**

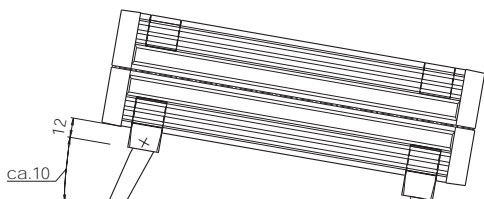

**Connecting Strap UM-VHH**

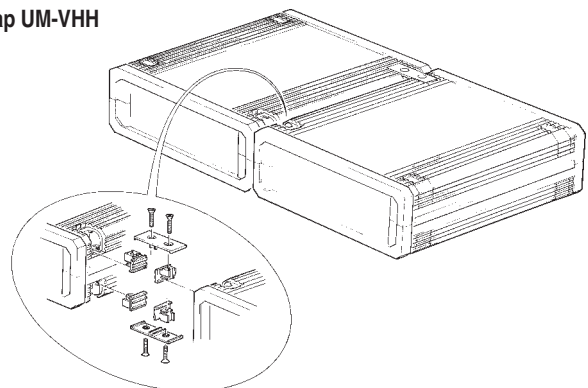

Dimensional Drawings