



ROSE+BOPLA
ENCLOSURES

A PHOENIX MECANO COMPANY

DIN Rail Mountable Enclosures CombiNorm Compact Product Drawings Last Updated 7/8/2008

Rose+Bopla Enclosures
7330 Executive Way
Frederick, MD 21704
301-696-9800
www.rose-bopla.com
rbinfo@pm-usa.com

For Secondary Services, Product Support, or To Order, Call 1-301-696-9800

DIN Rail Mountable Products



TECHNICAL DATA:

- Color: Light gray, similar to RAL 7035.
- Material: Polyamide 6.6 FR; front flap crystal clear polycarbonate.
- Flammability: UL 94 V0
- Surface Resistance: $>10^{15}$ Ohm to DIN 53482
- Ingress Protection:
 - IP 40 to DIN EN 60529 for complete enclosure without ventilation
 - IP 34 to DIN EN 60529 for complete enclosure with ventilation
 - IP 20 to DIN EN 60529 for terminals

The CombiNorm Compact is designed to easily house a circuit board in a flame resistant (UL94V0), Polyamide 6.6 shell and allow the choice of a lid and front panel. Lids are available with or

CombiNorm Compact

without terminal trim and air vents and simply snap into place. The orientation and design of the unit itself allows for optimal PC Board utilization because the PC Board is inserted from the side. External connections are located at angles which permit easy access for connecting and disconnecting leads. Front panel design is also simplified.

As its name "Compact" indicates this unit measures approximately 75mm high, 100mm deep, and is available in 3 standard widths ranging from 19mm to 26mm. Front panels are ideal for RF connectors and "D" or "Sub-D" connectors, 2-pin or 3-pin terminal blocks are stacked in openings on the top and bottom of the enclosure to maximize the number or potential connections without increasing the overall width of the unit. Right angle terminal soldering pins make it possible to mount terminals with components in a single soldering process.

CombiNorm Compact				
Part Number	Width Inches/mm	Length Inches/mm	Height Inches/mm	Maximum Terminals Assignment
CN 19	0.74/19.0	3.96/100.8	2.95/75.0	4 x 2 poles
CN 22	0.88/22.5	3.96/100.8	2.95/75.0	4 x 3 poles
CN 26	1.02/26.0	3.96/100.8	2.95/75.0	4 x 3 poles

Note: Dimensions are external. Metric is the primary dimension. Inch conversions and weights are for the user's convenience and are for reference only.

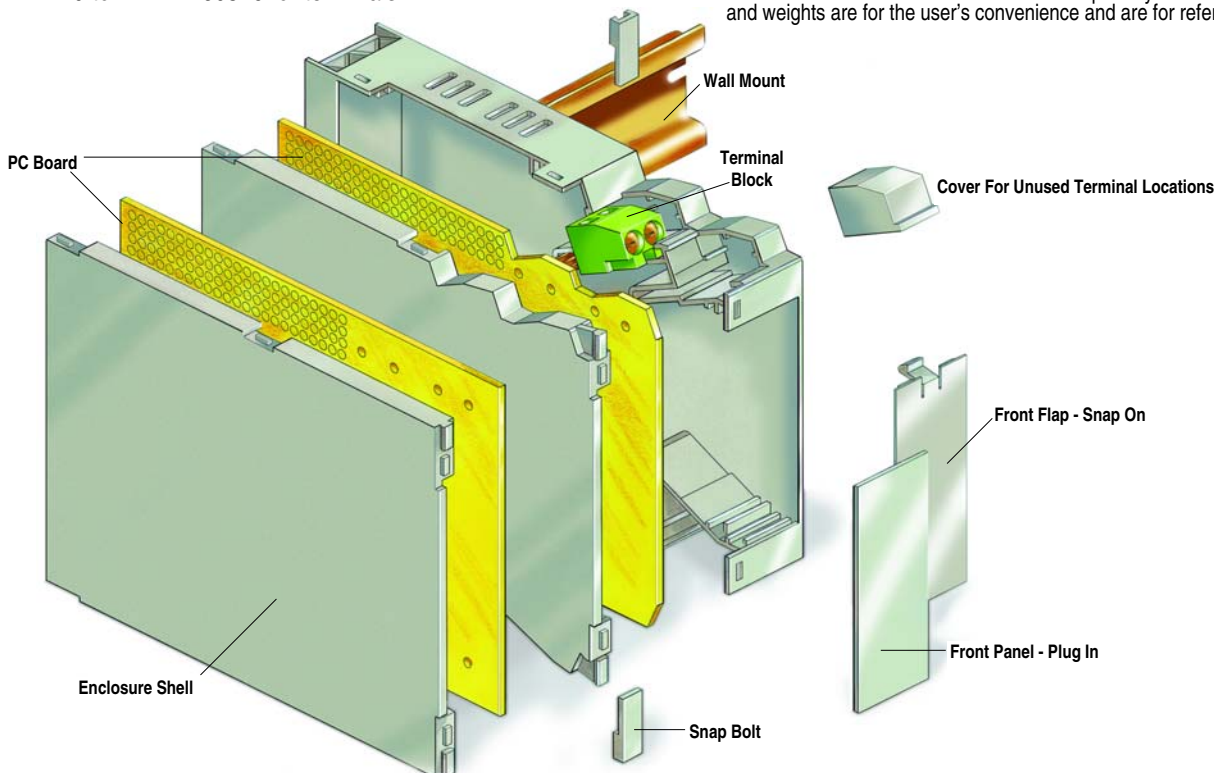

CombiNorm Compact Components

CombiNorm Compact CN 19 (max. 8 pole)					
Model Number	Part Number	Description	Enclosure width/mm	Drawing Page #	
CN 19 GK	65019100	Enclosure shell, contoured for max. 4x2-pole terminals	19	17-290	
CN 19 GK-L	65019110	Enclosure shell, contoured, with air vents for max. 4x2 pole terminals	19	17-290	
CN 19 GU	65019000	Enclosure shell, universal	19	17-290	
CN 19 GU-L	65019010	Enclosure shell, universal, with air vents (on request)	19	17-290	



CN 19 GK-L with CN-DK - Left
CN 19 GK with CN-DU - Right

CombiNorm Compact CN 19 Enclosure Lids					
Model Number	Part Number	Description	For Enclosure Shell	Drawing Page #	
CN-DK	65000200	Enclosure shell, contoured	GK (L)	17-290	
CN-DU	65000100	Enclosure shell, universal	GK (L), GU (L)	17-290	

CombiNorm Compact CN 19 Front Panel				
Model Number	Part Number	Description	For Enclosure Width/mm	
CN 19 FP	65019500	Front panel, plug-in, direction of insertion coded	19	

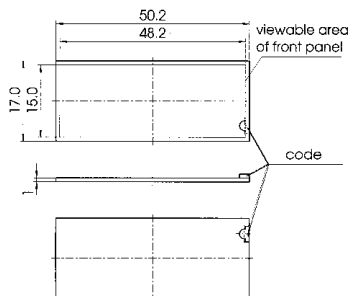

The **CN-FP** front panels are coded in their direction of insertion. Customer-specific front panels, e.g. made of aluminum, are also available as alternatives. A PCB plug-in slot for the mounting of front operating elements is provided parallel to the front panels. Instead of a front panel, a **CN..FK(G)** front flap (RAL 7035 or clear) can be snapped in. It can be removed for operation of rear components.



CN 19 GU with CN-DU

CombiNorm Compact CN 19 Front Flaps				
Model Number	Part Number	Description	For Enclosure Width/mm	
CN 19 FK	65019600	Front flap, snap-on	19	
CN 19 FKG	65019700	Front flap, snap-on, clear	19	

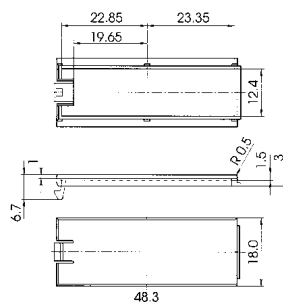

Instead of a front panel, a **CN..FK(G)** front flap (RAL 7035 or clear) can be snapped in. It can be removed for operation of the rear components.

Different enclosure combinations using shells and lids offer various advantages:

CN..GK with CN-DK: This combination requires the PCB to have a stepped profile. Optimal access to terminals of enclosures which are connected to each other.

CN..GK with CN-DU: This combination permits the use of a rectangular (grooved) PCB which minimizes production costs.

CN..GU with CN-DU: Universal enclosure without pre-set terminal positions, permitting the use of larger bus wire connectors parallel to the PCB (upper or lower). Accessories shown on drawing page.

CombiNorm Compact Components

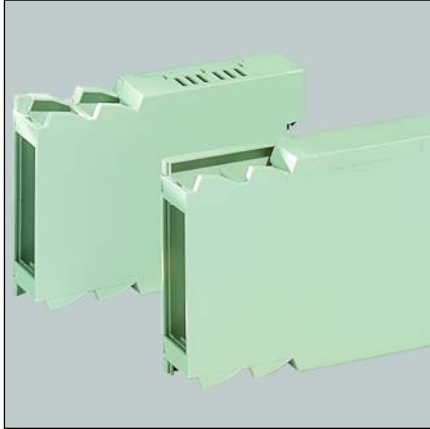

CN 22 GK-L with CN-DK - Left
CN 22 GK with CN-DU - Right

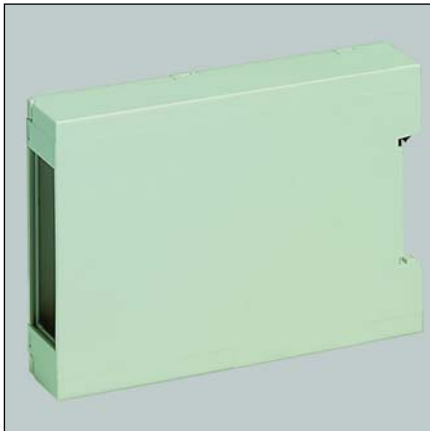

CN 22 GU with CN-DU

Different enclosure combinations using shells and lids offer various advantages:

CN..GK with CN-DK: This combination requires the PCB to have a stepped profile. Optimal access to terminals of enclosures which are connected to each other.

CN..GK with CN-DU: This combination permits the use of a rectangular (grooved) PCB which minimizes production costs.

CN..GU with CN-DU: Universal enclosure without pre-set terminal positions, permitting the use of larger bus wire connectors parallel to the PCB (upper or lower). Accessories shown on drawing page.

CombiNorm Compact CN 22 (max. 12 pole)				
Model Number	Part Number	Description	Enclosure width/mm	Drawing Page #
CN 22 GK	65022100	Enclosure shell, contoured, for max. 4x3-pole terminals	22.5	17-291
CN 22 GK-L	65022110	Enclosure shell, contoured, with air vents for max. 4x3 pole terminals	22.5	17-291
CN 22 GU	65022000	Enclosure shell, universal	22.5	17-291
CN 22 GU-L	65022010	Enclosure shell, universal, with air vents (on request)	22.5	17-291

CombiNorm Compact CN 22 Enclosure Lids				
Model Number	Part Number	Description	For Enclosure Shell	Drawing Page #
CN-DK	65000200	Enclosure shell, contoured	GK (L)	17-291
CN-DU	65000100	Enclosure shell, universal	GK (L), GU (L)	17-291

CombiNorm Compact CN 22 Front Panel			
Model Number	Part Number	Description	For Enclosure Width/mm
CN 22 FP	65022500	Front panel, plug-in, direction of insertion coded	22.5

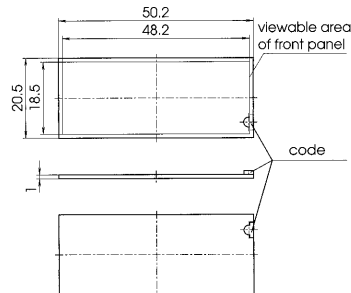

The **CN-FP** front panels are coded in their direction of insertion. Customer-specific front panels, e.g. made of aluminum, are also available as alternatives. A PCB plug-in slot for the mounting of front operating elements is provided parallel to the front panels. Instead of a front panel, a CN..FK(G) front flap (RAL 7035 or clear) can be snapped in. It can be removed for operation of rear components.

CombiNorm Compact CN 19 Front Flaps			
Model Number	Part Number	Description	For Enclosure Width/mm
CN 22 FK	65022600	Front flap, snap-on	22.5
CN 22 FKG	65022700	Front flap, snap-on, clear	22.5

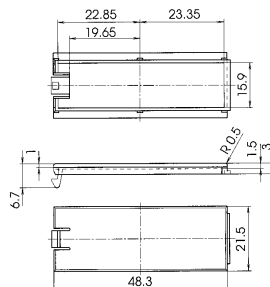

Instead of a front panel, a **CN..FK(G)** front flap (RAL 7035 or clear) can be snapped in. It can be removed for operation of rear components.

CombiNorm Compact Components

CombiNorm Compact CN 26 (max. 12 pole)				
Model Number	Part Number	Description	Enclosure width/mm	Drawing Page #
CN 26 GK	65026100	Enclosure shell, contoured, for max. 4x3-pole terminals	26	17-292
CN 26 GK-L	65026110	Enclosure shell, contoured, with air vents for max. 4x3 pole terminals	26	17-292
CN 26 GU	65026000	Enclosure shell, universal	26	17-292
CN 26 GU-L	65026010	Enclosure shell, universal, with air vents (on request)	26	17-292

CombiNorm Compact CN 26 Enclosure Lids				
Model Number	Part Number	Description	For Enclosure Shell	Drawing Page #
CN-DK	65000200	Enclosure shell, contoured	GK (L)	17-292
CN-DU	65000100	Enclosure shell, universal	GK (L), GU (L)	17-292

CombiNorm Compact CN 26 Front Panel			
Model Number	Part Number	Description	For Enclosure Width/mm
CN 26 FP	65026500	Front panel, plug-in, direction of insertion coded	26

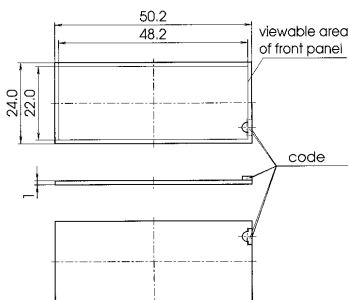

The **CN-FP** front panels are coded in their direction of insertion. Customer-specific front panels, e.g. made of aluminum, are also available as alternatives. A PCB plug-in slot for the mounting of front operating elements is provided parallel to the front panels. Instead of a front panel, a CN..FK(G) front flap (RAL 7035 or clear) can be snapped in. It can be removed for operation of rear components.

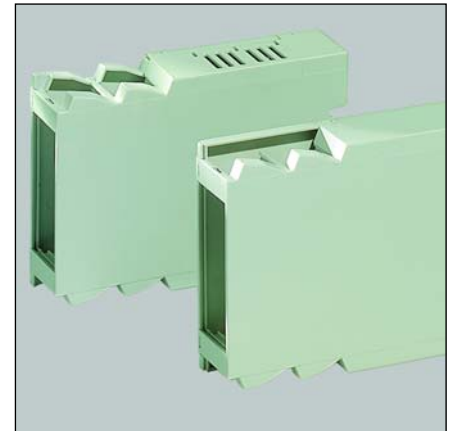

CN 26 GK-L with CN-DK - Left
CN 26 GK with CN-DU - Right



CN 26 GU with CN-DU

CombiNorm Compact CN 26 Front Flaps			
Model Number	Part Number	Description	For Enclosure Width/mm
CN 26 FK	65026600	Front flap, snap-on	26
CN 26 FKG	65026700	Front flap, snap-on, clear	26

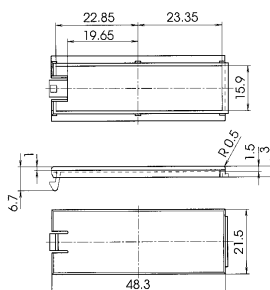

Instead of a front panel, a **CN..FK(G)** front flap (RAL 7035 or clear) can be snapped in. It can be removed for operation of the rear components.

Different enclosure combinations using shells and lids offer various advantages:

CN..GK with CN-DK: This combination requires the PCB to have a stepped profile. Optimal access to terminals of enclosures which are connected to each other.

CN..GK with CN-DU: This combination permits the use of a rectangular (grooved) PCB which minimizes production costs.

CN..GU with CN-DU: Universal enclosure without pre-set terminal positions, permitting the use of larger bus wire connectors parallel to the PCB (upper or lower). Accessories shown on drawing page.

Din Rail Mountable Enclosures

CN 19 GK (L)

External Dimensions: L 100.8 x W 19.0 x H 75.0 mm

Page 4-1, 4-3

Standard Features
<ul style="list-style-type: none"> • CN 19 GK/65019100 Enclosure shell, contoured, for max. 4x2 pole terminals. • CN 19 GK-L/65019110 Enclosure shell, contoured, with air vents for max. 4x2 pole terminals.
Accessories
<ul style="list-style-type: none"> • CN-BZ/66000022 Marking plate for clipping onto upper and lower section of enclosure front. • CN-BL 1/66000032 Blind piece, 1-pole for unused terminal locations. • CN-BL 2/66000042 Blind piece, 2-pole for unused terminal locations. • CN-WA/66000012 Wall mount adapter. • CN-DK/650000200 Lid for enclosure shell, contoured. • CN-DU/65000100 Lid for enclosure shell, universal. • CN 19 FP/65019500 Front panel, plug-in. Direction of insertion coded. • CN 19 FK/65019600 Front flap, snap-on. • CN 19 FKG/65019700 Front flap, snap-on, clear. • AK-BS/66000100 Terminal identification strip, self-adhesive. • AK 8191/2DL/66000052 2-pole, on left of component side (seen from front), PCB vertical. • AK 8191/2DR/66000062 2-pole, on right of component side (seen from front), PCB vertical.

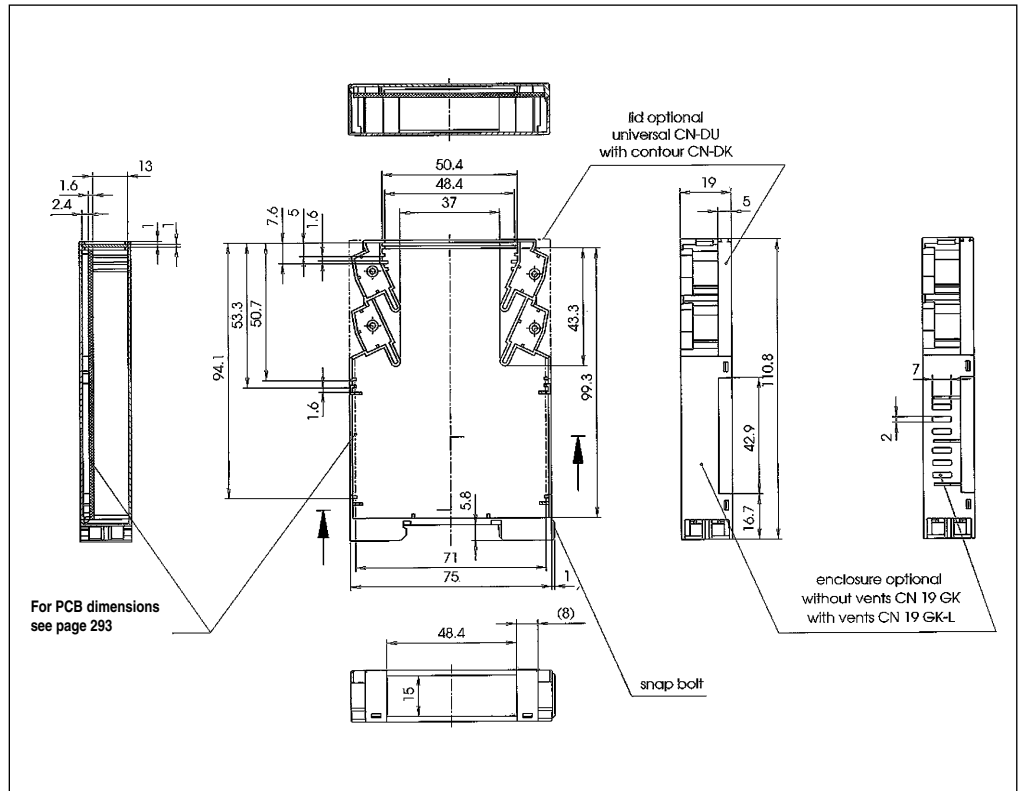

CN 19 GU (L)

External Dimensions: L 100.8 x W 19.0 x H 75.0 mm

Page 4-1, 4-3

Standard Features
<ul style="list-style-type: none"> • CN 19 GU/65019000 Enclosure shell, universal. • CN 19 GU-L/65019010 Enclosure shell, universal, with air vents (on request).
Accessories
<ul style="list-style-type: none"> • CN-BZ/66000022 Marking plate for clipping onto upper and lower section of enclosure front. • CN-WA/66000012 Wall mount adapter. • CN-DU/65000100 Lid for enclosure shell, universal. • CN 19 FP/65019500 Front panel, plug-in. • CN 19 FK/65019600 Front flap, snap-on. • CN 19 FKG/65019700 Front flap, snap-on, clear.

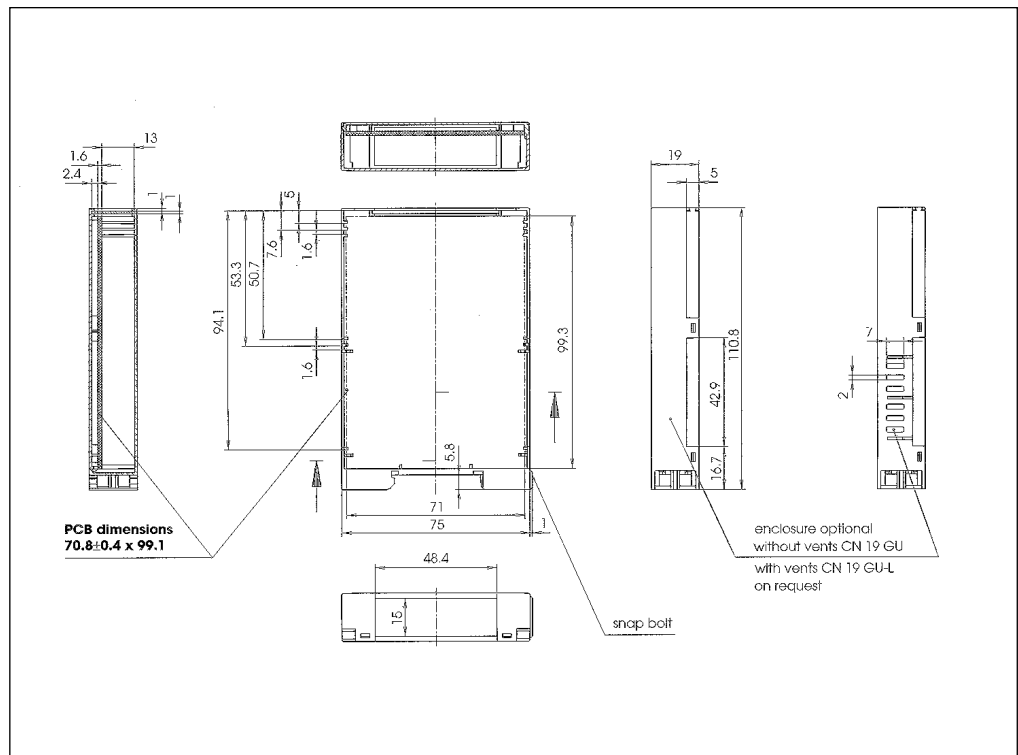



CN 22 GK (L)

External Dimensions: L 100.8 x W 22.5 x H 75.0 mm

Page 14-1, 14-4

Standard Features

- CN 22 GK/65022100 Enclosure shell, contoured, for max. 4x3-pole terminals.
- CN 22 GK-L/65022110 Enclosure shell, contoured, with air vents for max. 4x3-pole terminals.

Accessories

- CN-BZ/66000022 Marking plate for clipping onto upper and lower section of enclosure front.
- CN-BL 1/66000032 Blind piece, 1-pole for unused terminal locations.
- CN-BL 2/66000042 Blind piece, 2-pole for unused terminal locations.
- CN-WA/66000012 Wall mount adapter.
- CN-DU/65000200 Lid for enclosure shell - Contoured.
- CN-DU/65000100 Lid for enclosure shell - Universal.
- CN 22 FP/65022500 Front panel, plug-in. Direction of insertion coded.
- CN 22 FK/65022600 Front flap, snap-on.
- CN 22 FKG/65022700 Front flap, snap-on, clear.
- AK-BS/66000100 Terminal identification strip, self-adhesive.
- AK 8191/3DL/66000072 3-pole, on left of component side (seen from front), PCB vertical.
- AK 8191/3DR/66000082 3-pole, on right of compartment side (seen from front), PCB vertical.

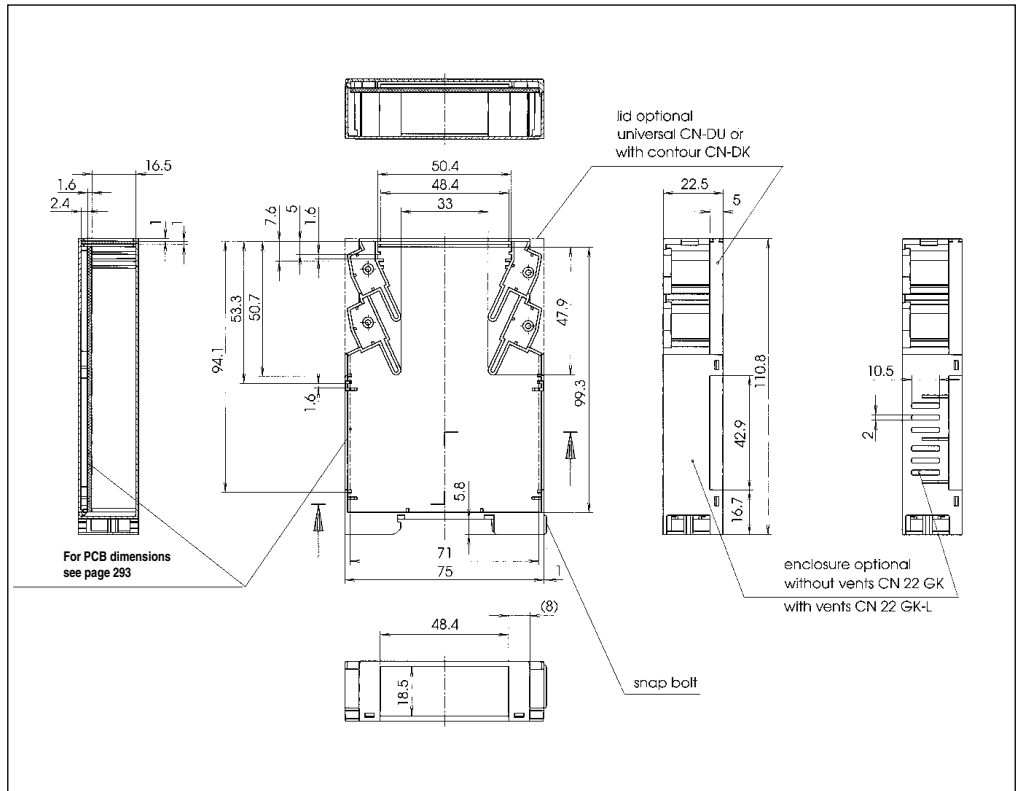

CN 22 GU (L)

External Dimensions: L100.8 x W 22.5 x H 75.0 mm

Page 14-1, 14-4

Standard Features

- CN 22 GU/65022000 Enclosure shell, universal.
- CN 22 GU-L/65022010 Enclosure shell, universal, with air vents (on request).

Accessories

- CN-BZ/66000022 Marking plate for clipping onto upper and lower section of enclosure front.
- CN-WA/66000012 Wall mount adapter.
- CN-DU/65000100 Lid for enclosure shell - universal.
- CN 22 FP/65022500 Front panel, plug-in. Direction of insertion coded.
- CN 22 FK/65022600 Front flap, snap-on.
- CN 22 FKG/65022700 Front flap, snap-on, clear.

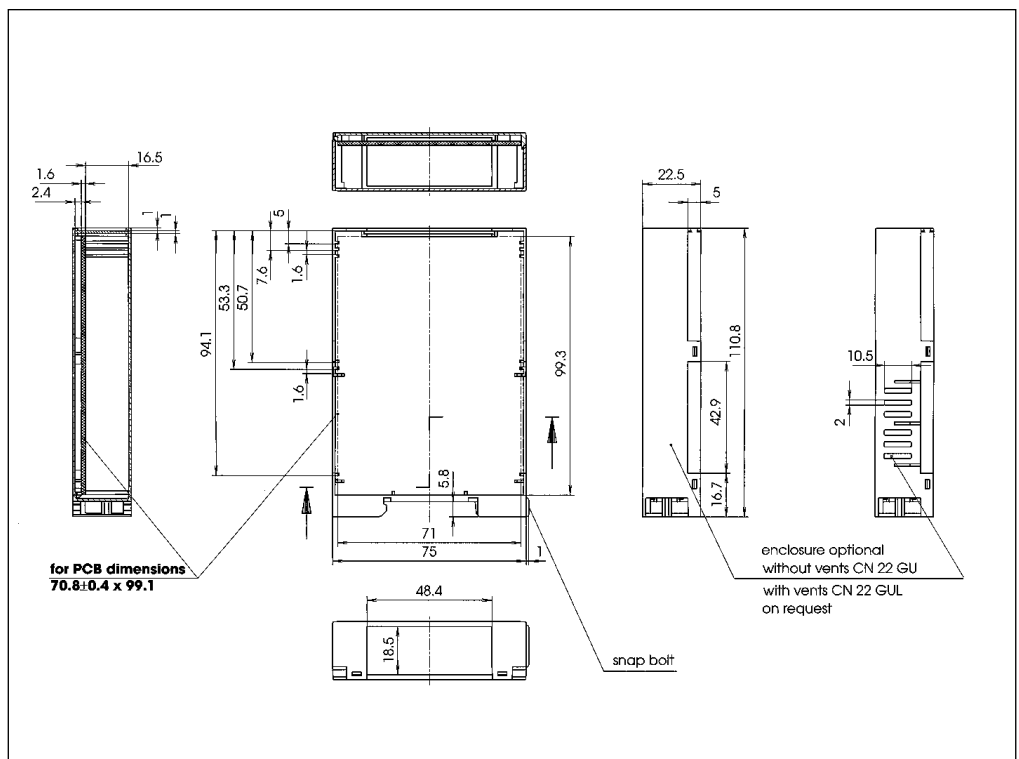

Din Rail Mountable Enclosures

CN 26 GK(L)

External Dimensions: L100.8 x W 26.0 x H 75.0 mm

Page 14-1, 14-5

Standard Features

- CN 26 GK/65026100 Enclosure shell, contoured, for max. 4x3 pole terminals.
- CN 26 GK-L/65026110 Enclosure shell, contoured, with air vents for max. 4x3 pole terminals.

Accessories

- CN-BZ/66000022 Marking plate for clipping onto upper and lower section of enclosure front.
- CN-BL 1/66000032 Blind piece, 1-pole for unused terminal locations.
- CN-BL 2/66000042 Blind piece, 2-pole for unused terminal locations.
- CN-WA/66000012 Wall mount adapter.
- CN-DK/65000200 Lid for enclosure shell, contoured.
- CN-DU/65000100 Lid for enclosure shell, universal.
- CN 26 FP/65026500 Front panel, plug-in. Direction of insertion coded.
- CN 26 FK/65026600 Front flap, snap-on.
- CN 26 FKG/65026700 Front flap, snap-on, clear.
- AK-BS/66000100 Terminal identification strip, self-adhesive.
- AK 8191/3DL/66000072 3-pole, on left of component side (seen from front), PCB vertical.
- AK 8191/3DR 3-pole, on right of compartment side (seen from front), PCB vertical.

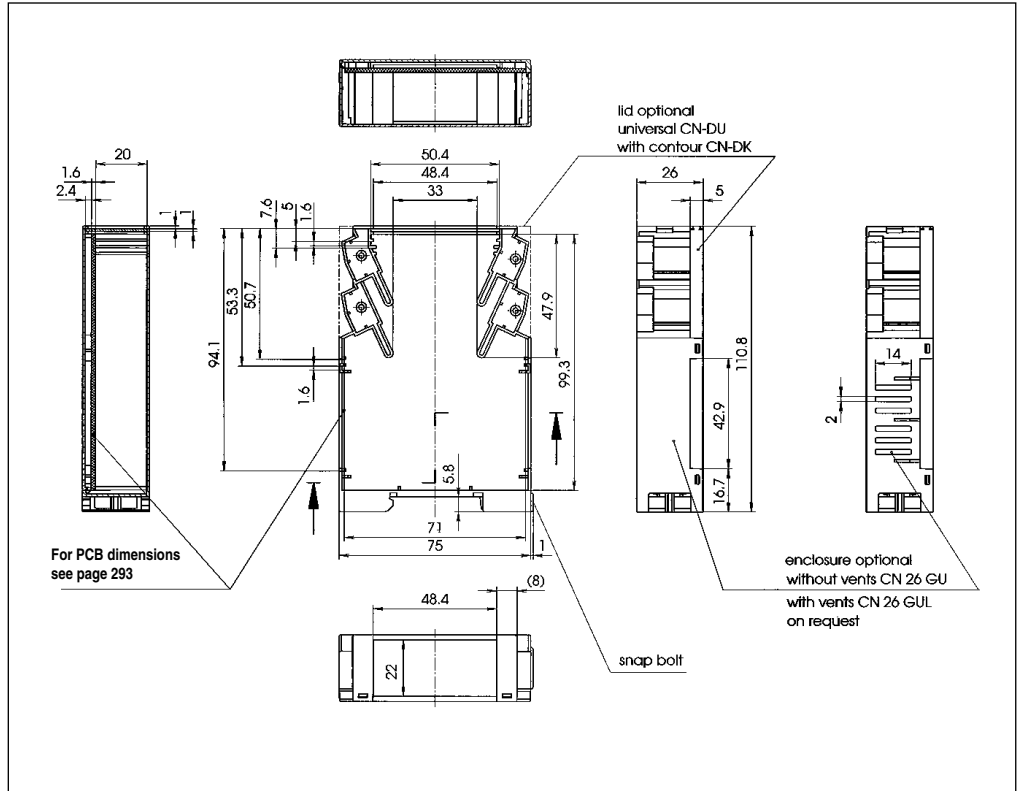

CN 26 GU (L)

External Dimensions: L 100.8 x W 26.0 x H 75.0 mm

Page 14-1, 14-5

Standard Features

- CN 26 GU/65026000 Enclosure shell, universal.
- CN 26 GU-L/65026010 Enclosure shell, universal with air vents (on request).

Accessories

- CN-BZ/66000022 Marking plate for clipping onto upper and lower section of enclosure front.
- CN-WA/66000012 Wall mount adapter.
- CN-DU/65000200 Lid for enclosure shell, universal.
- CN 26 FP/65026500 Front panel, plug-in. Direction of insertion coded.
- CN 26 FK/65026600 Front flap, snap-on.
- CN 26 FKG/65026700 Front flap, snap-on, clear.

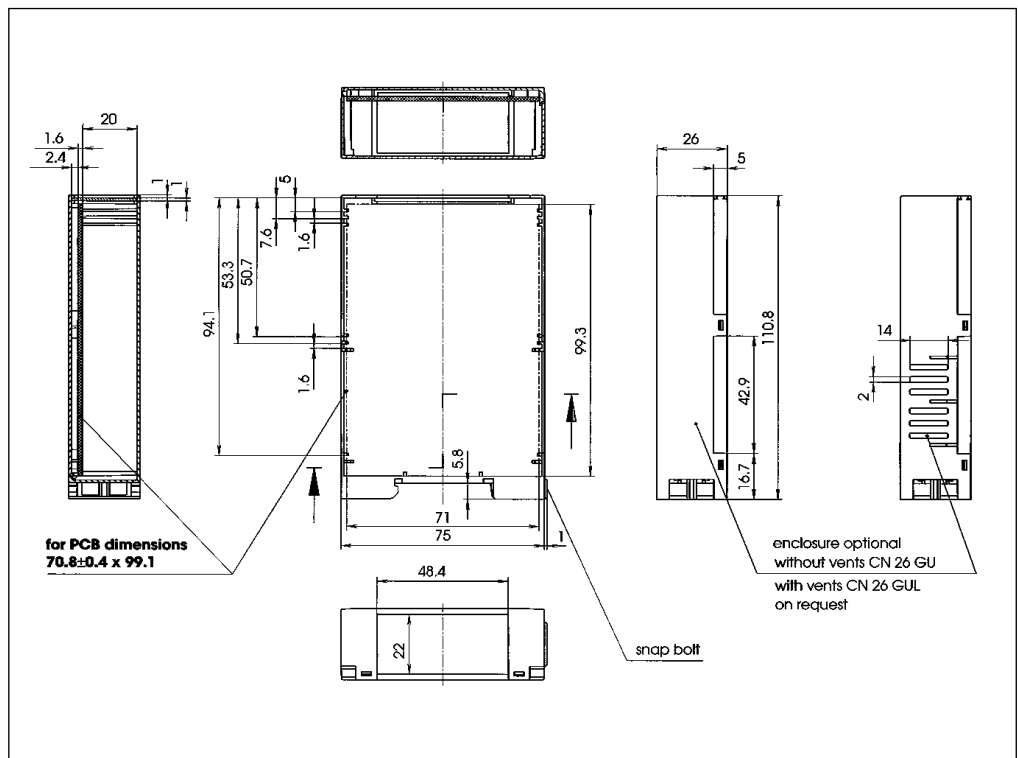

Combi-Norm Compact Accessories

Connection Terminals

Standard Features

- **AK 8191/2DL/66000052** 2-pole, on left of component side (seen from front), PCB vertical.
- **AK 8191/2DR/66000062** 2-pole, on right of component side (seen from front), PCB vertical.
- **AK 8191/3DL/66000072** 3-pole, on left of component side (seen from front), PCB vertical.
- **AK 8191/3DR/66000082** 3-pole, on right of component side (seen from front), PCB vertical.

AK 8191/2DL

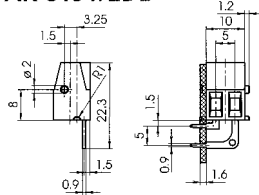

AK 8191/2DR

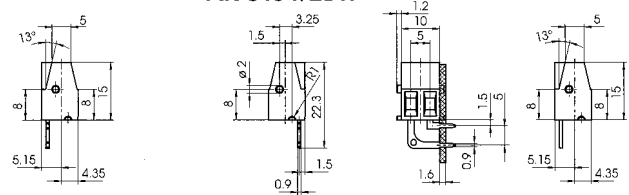

AK 8191/3DL

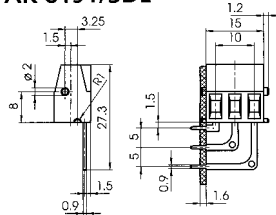

AK 8191/3DR

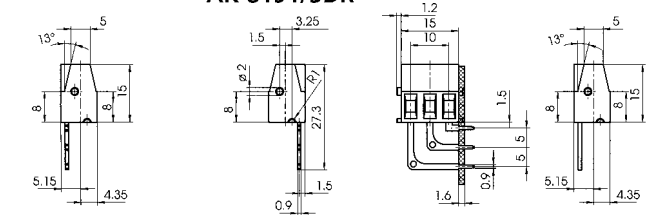

Rated cross-section: 2.5mm²
Max. connection cross-section:
 Single wire (rigid) 0.14-4 mm²
 Fine-strand (flexible) 0.14 - 2.5mm²
Rated current: 16 A

Rated voltage according to VDE 110/01.89:
 250V/4KV/3 overvoltage category III
 *690V/4KV/2 overvoltage category II
 1000V/4KV/1 overvoltage category I

* max. 600 V for earthed equipment or expected overvoltage

PCB Dimensions for CombiNorm Compact

PCB dimensions for CN..GK with CN..DK or CN..DU

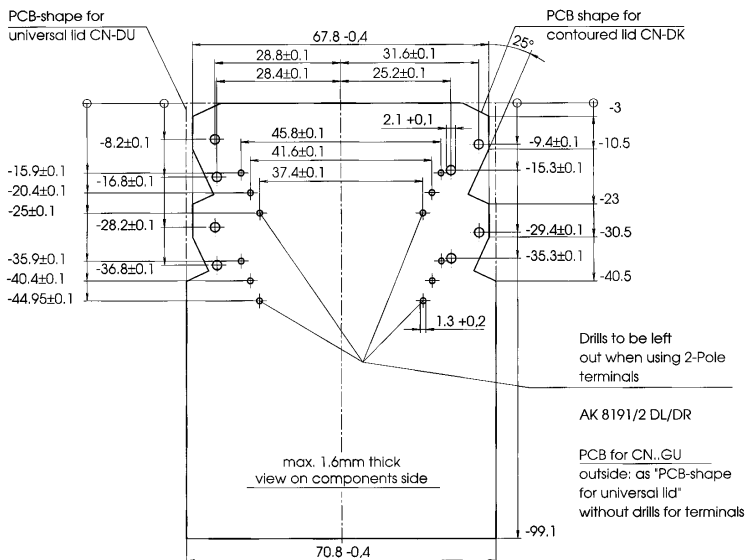

Load-bearing capacity

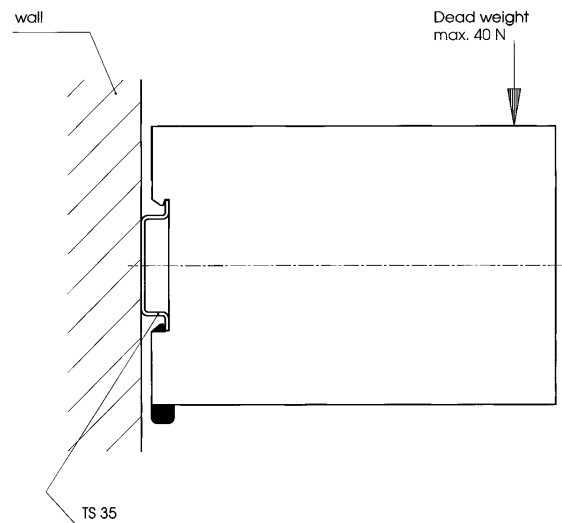

Dimensional Drawings